

DAYTONA 350



CONTENTS

ENGINE PART

CYLINDER HEAD ASSY	4
CYLINDER ASSY	5
CRANKCASE ASSY	6
CRANKSHAFT CONNECTING ROD PISTON ASSY	7
ALLOT AIR ORGANIZATION ASSY	8
OIL PUMP ASSY	9
CLUTCH ASSY	10
LEFT CRANKCASE COVER ASSY	11
CRABURETOR ASSY	12
ELECTRICITY STARTING ASSY	13
ELECTRICAL SYSTEM	14
RIGHT CRANKCASE COVER ASSY	15
LEFT REAR CRANKCASE COVER ASSY	16
TRANSMISSION ASSY	17
TRANSMISSION ASSY	18
WATER PUMP ASSY	19
WATER PUMP ASSY	20
COOLING SYSTEM	21

CHASIS PART

CHASIS	22
LIGHTS AND MAIN CABLE	23
BATTERY	24
SWITCH L.R AND GUY CABLE	25
SWITCH L.R AND GUY CABLE	26
SWITCH L.R AND GUY CABLE	27
FRONT SHAKER FRAME AND SPEEDODOMETER	28
FRONT SUSPENSION AND FRONT FENDER.REAR SHOCK ABSORBER	29
FRONT WHEEL	30
FRONT & REAR BRAKE PUMP ASSY	31
REAR WHEEL	32
FUEL TANK AND FUEL SWITCH	33
SEAT	34
SHIFT GEAR SYSTEM AND SHIFTER	35
REAR BRAKE POLE	36
AIR FILTER ASSY	37
EXHAUST-GAS MUFFLER	38
EXHAUST-GAS MUFFLER	39
REAR FENDER	40
SIDE COVER AND WIRE BOX	41
REAR SWING ARM AND CHAIN COVER	42
LEFT & RIGHT PASSENGER'S PEDAL	43
Kettle and Radiator	44
Engine Parts	45

E-1: 气缸盖总成 (Cylinder head assembly) 新开模具

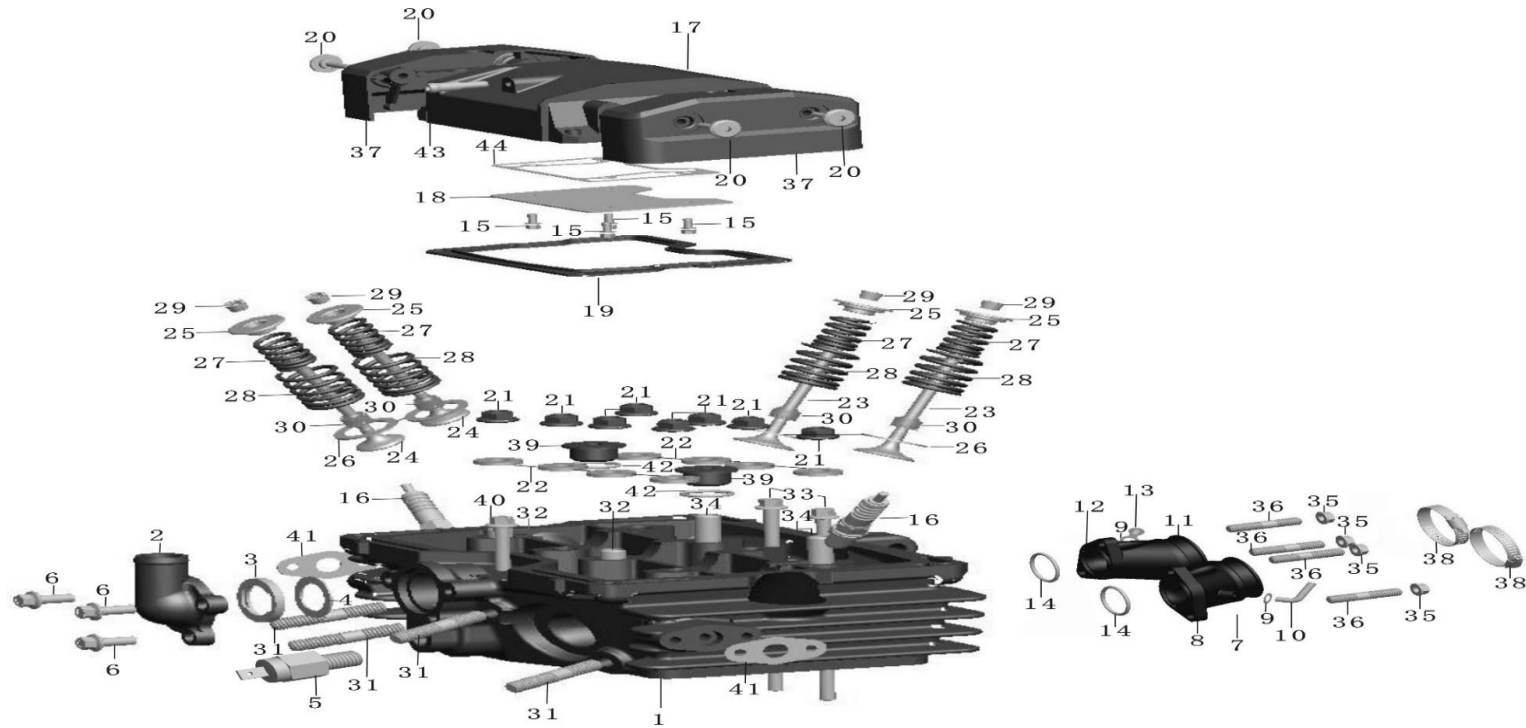

NO	PART CODE	DESCRIPTION	QTY	NO	PART CODE	DESCRIPTION	QTY
1	2.22.0101.10008	Head comp ,cylinder	1	26	2.20.0101.01100	Seat, valve spring outer	4
2	2.22.0101.02508	Hose connector,cyliner,black	1	27	2.20.0101.01200	Spring, valve inner	4
3	2.23.0117.32200	Rusher,thermosat	1	28	2.20.0101.01300	Spring, valve outer	4
4	2.23.0117.32100	Rubber seat,thermosat	1	29	2.20.0101.01400	Cotter, valve	8
5	2.23.0117.31000	Tem sensor	1	30	2.20.0101.02000	Seal, valve stem	4
6	2.20.0108.0040S	Bolt M6 x 20	3	31	2.20.0101.0150R	Bolt stud of escape pipe	4
7	2.22.0101.20000	Left manifold, intake	1	32	2.20.0101.01600	Pin, dowel 10 x 16	2
11	2.22.0101.30000	Right manifold, intake	1	33	2.20.0101.0170R	Bolt M6 x 145	2
14	2.20.0101.20200	O-ring Φ26 x 2.5	2	34	2.20.0101.01900	Pin, dowel 10 x 28	2
15	2.99.26.060120R	Bolt M6 x 12	4	35	2.99.43.060000R	Nut M6-ZnD	4
16	2.30.0101.50020	NGK	2	36	2.20.0101.0220R	Bolt stud M6 x 29	4
17	2.19.0101.00108	Cover, cylinder head	1	37	2.23.0101.0230S	Side cover, cylinder head	2
18	2.19.0101.04200	Coverplate,cyliner cover	1	38	2.20.0101.03000	Band insulator 1 x 44	2
19	2.20.0101.00300	Packing ,head cover	1	39	2.33.0101.10700	Bolt stops	2
20	2.20.0101.0040S	Connect screw of cover	4	40	2.23.0101.0180S	Bolt M6 x 83	1
21	2.20.0101.0050R	Nut, hex M8 x 4	8	41	2.20.0101.61200	Gasket	2
22	2.20.0101.0060R	Washer 8	8	42	2.23.0101.10100	O-ring Φ15.2 x 2.5	2
23	2.22.0101.00700	Valve, in	2	43	2.20.0103.1090R	Rubber pipe cover	1
24	2.22.0101.00800	Valve, ex	2	44	2.19.0101.04110	Gasket,cyliner cover (non asbestos)	1
25	2.20.0101.00900	Retainer, valve spring	4				

E-2: 气缸体总成 (Cylinder assembly)

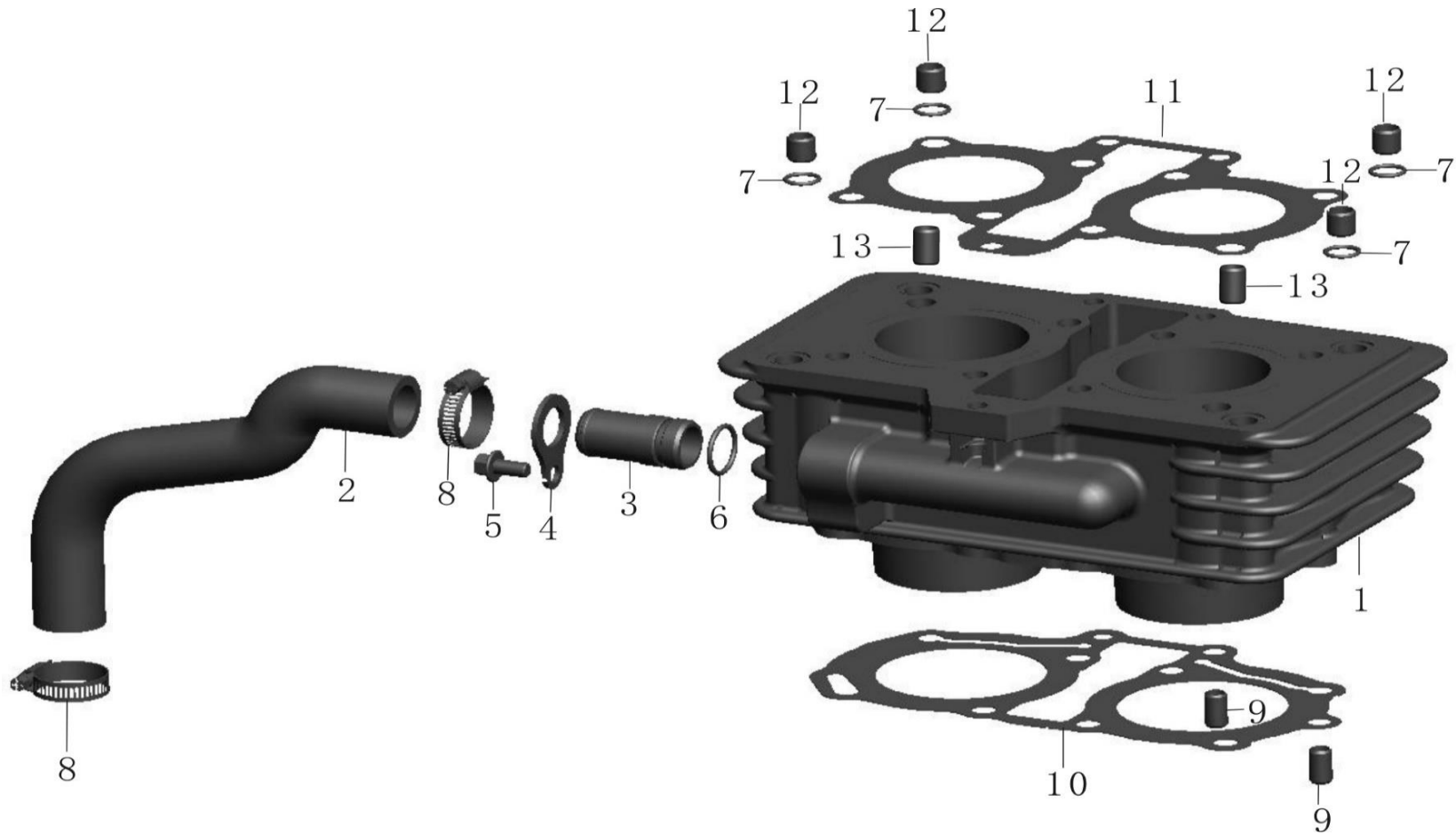

NO	PART CODE	DESCRIPTION	QTY
1	2.22.0102.10008	Cylinder comp	1
2	2.23.0102.00400	Hose, cylinder	1
3	2.23.0101.0250S	Hose connector	1
4	2.23.0101.0240S	Hose connector setting plate	1
5	2.99.26.060120S	Bolt M6 x 12	1
6	2.23.0101.02600	O-ring $\Phi 17 \times 2$	1
7	2.20.0101.10300	O- ring $\Phi 10 \times 1.6$	4
8	2.23.0117.01000	Hose clip	2
9	2.20.0102.00100	Pin,dowel $\Phi 8 \times 14$	2
10	2.22.0102.00200	Gasket,cylinder	1
11	2.22.0102.00300	Gasket,cylinder head	1
12	2.23.0102.00600	Pin,dowel 10 x 10	4
13	2.20.0101.01600	Pin,dowel $\Phi 10 \times 16$	2

E-3: 曲轴箱总成 (Crankcase assembly) -带档显



NO	PART CODE	DESCRIPTION	QTY	NO	PART CODE	DESCRIPTION	QTY
1	2.22.0103.19003	Left crankcase	1	23	2.20.0103.00500	Pin,dowel 12 x 20	2
2	2.99.26.060120R	Bolt M6 x 12	1	24	2.20.0103.00610	Gasket,side spacer	1
3	2.20.0103.17000	Transmishion indercator	1	25	2.22.0103.00720	Gasket,crankcase	1
4	2.20.0103.02200	Pin,shift	1	26	2.20.0108.0060S	Bolt M6 x 65	2
5	2.20.0102.00100	Pin,dowel 8 x 14	4	27	2.20.0103.0110R	Screw M12 x 1.5	1
6	2.20.0103.10700	Jacket, outlet	1	28	2.20.0103.01200	Washer 12	1
7	2.20.0103.1090R	Rubber pipe cover	1	29	2.20.0103.01500	Bolt, cylinder head stud	8
8	2.20.0103.11100	O-ring 6 x 3	2	30	2.20.0103.0160R	Bolt M8 x 1 x 35	4
9	2.99.05.060160R	Screw M6 x 16	3	31	2.22.0103.02300	Bolt M7 x 1 x 19	1
10	2.20.0103.12000	Plate, oil through	1	32	2.99.05.060320R	Screw M6x32-ZnD	3
11	2.99.70.0630500	Bearing 6305/P6	2	33	2.20.0103.10100	Sleeve	1
12	2.20.0103.13000	Oil seal 35 x 52 x 7	1	34	2.20.0103.10200	Sleeve	1
13	2.99.70.0620200	Bearing 6202-Z/P6	1	35	2.52.0103.09200	Screen ,oil filter	1
14	2.20.0103.14000	Bearing 22 x 47 x 14-RS/P6	1	36	2.19.0112.00400	Spring,oil filter	1
15	2.20.0103.15000	Oil seal 22 x 34 x 7	1	37	2.90.0101.01800	O-ring 30.8 x 3.2	1
16	2.20.0103.16000	Oil seal 11.6 x 24 x 10	1	38	2.90.0100.08300	Valve cover	1
17	2.22.0103.21003	Right crankcase	1	39	2.99.70.0630110	Bearing 6301/P5	2
18	2.99.70.0630400	Roller bearing 6304/P6	1	40	2.22.0106.02600	Seal ring,oil pump	1
19	2.20.0103.22000	Needle-bearing NK152312	1	41	2.22.0103.02400	Pressing plate, oil pump	1
20	2.22.0103.00100	Gasket,right crankcase cover	1	42	2.99.04.050080R	Screw M5 x 8	2
21	2.20.0112.0010S	Bolt M6 x 40	8	43	2.22.0103.02500	O-ring 8 x 3	1
22	2.20.0103.0210R	Bolt M8 x 1 x 30	1				

E-4: 曲轴连杆总成 (Crankshaft connecting rod piston assembly)

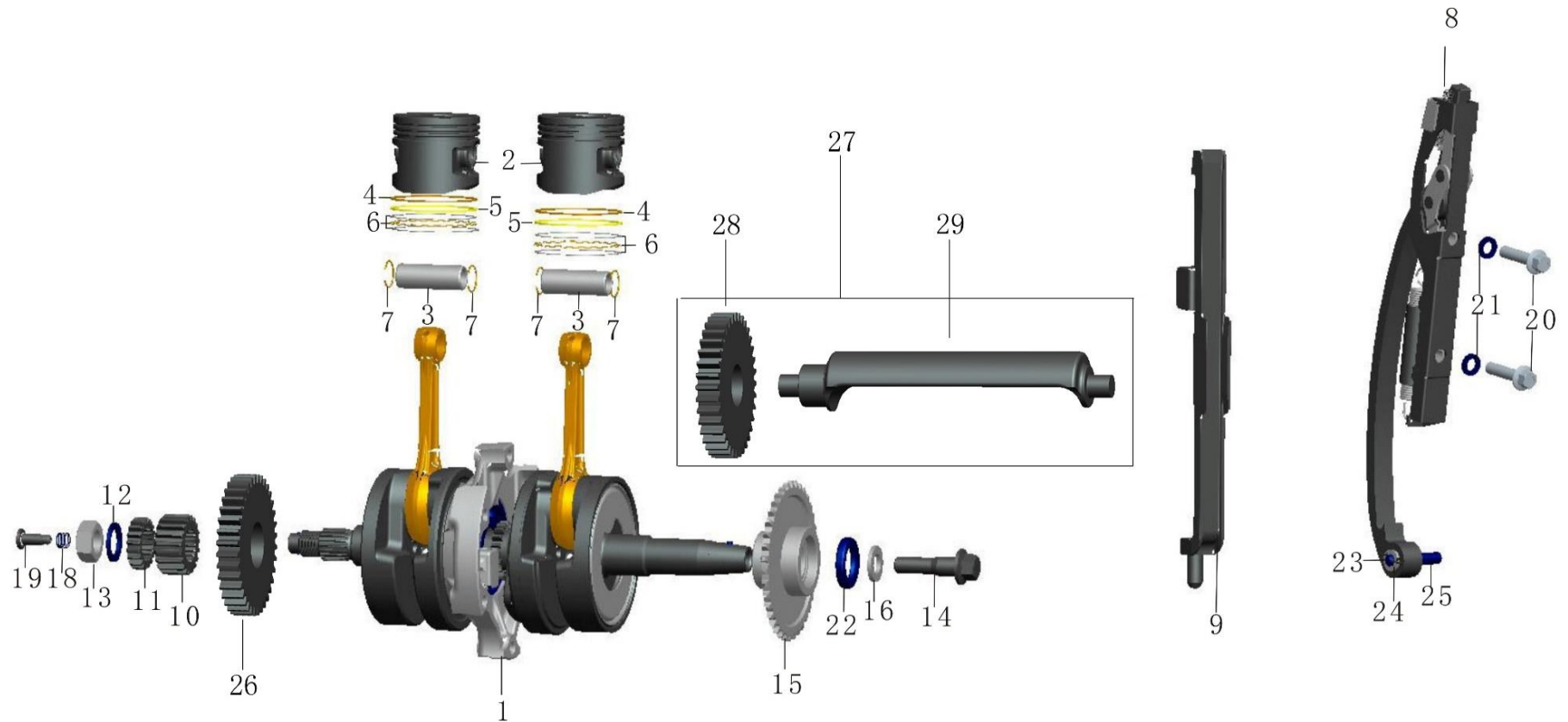

NO	PART CODE	DESCRIPTION	QTY	NO	PART CODE	DESCRIPTION	QTY
1	2.22.0104.10020	Crankshaft comp	1	13	2.20.0104.0050R	Nut, hex M16 x 1	1
2	2.22.0104.20100	Piston	2	14	2.20.0104.0060R	Bolt, rotor setting	1
3	2.22.0104.20200	Pin, piston	2	15	2.20.0104.00700	Sprocket comp, starting	1
4	2.22.0104.20300	1st piston ring	2	16	2.20.0104.00800	Washer 12	1
5	2.22.0104.20400	2nd piston ring	2	17	2.20.0104.00900	Pin Φ2 x 14	1
6	2.22.0104.21000	Oil seal set	2	18	2.20.0104.01100	Spring, oil through	1
	2.22.0104.21100	Expander ring	2	19	2.20.0104.01200	Through oil	1
	2.22.0104.21200	Scaper	4	20	2.20.0104.0130R	Bolt M6 x 26	2
7	2.20.0104.20500	Clip, piston pin	4	21	2.20.0104.01400	Washer 6	2
8	2.20.0104.30020	Chain stretching comp	1	22	2.20.0104.02000	Oil seal 22 x 31 x 5	1
9	2.20.0104.00110	Guide, cam chain	1	23	2.20.0104.01500	Washer	1
10	2.20.0104.00200	Gear, primary drive	1	24	2.20.0104.01600	Flexible spring	1
11	2.23.0104.00300	Gear, oil pump drive	1	25		Pin B6 x 14	1
12	2.20.0104.00400	Washer, lock	1	27	2.22.0104.40000	Balance shaft assy	1

E-5: 配气机构总成 (Allot air organization assembly)

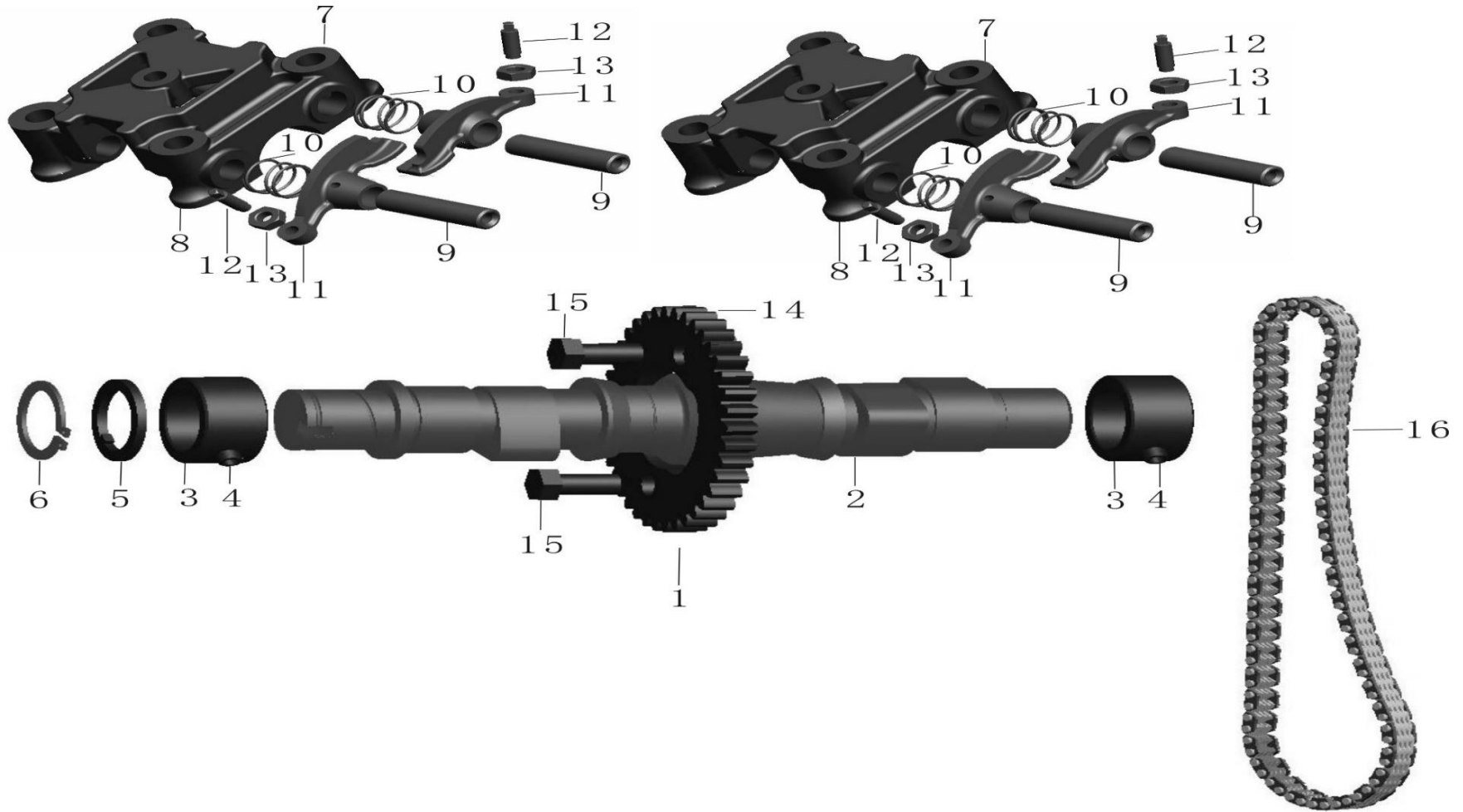

NO	PART CODE	DESCRIPTION	QTY
1	2.20.0105.10000	Camshaft	1
2	2.20.0105.10000	Camshaft	1
3	2.20.0105.10210	Bush, camshaft	2
4	2.20.0105.10300	Pin, dowel bush camshaft	2
5	2.99.63.0200000	Circlip, externa 20	1
6	2.20.0105.10500	Washer, thrust	1
7	2.22.0105.20000	Holder comp, camshaft M8	2
14	2.20.0105.00110	Sprocket, cam	1
15	2.20.0105.0020C	Bolt M7 x 13	2
16	2.20.0105.30000	Chain, cam	1

E-6: 机油泵总成 (Oil pump assembly)

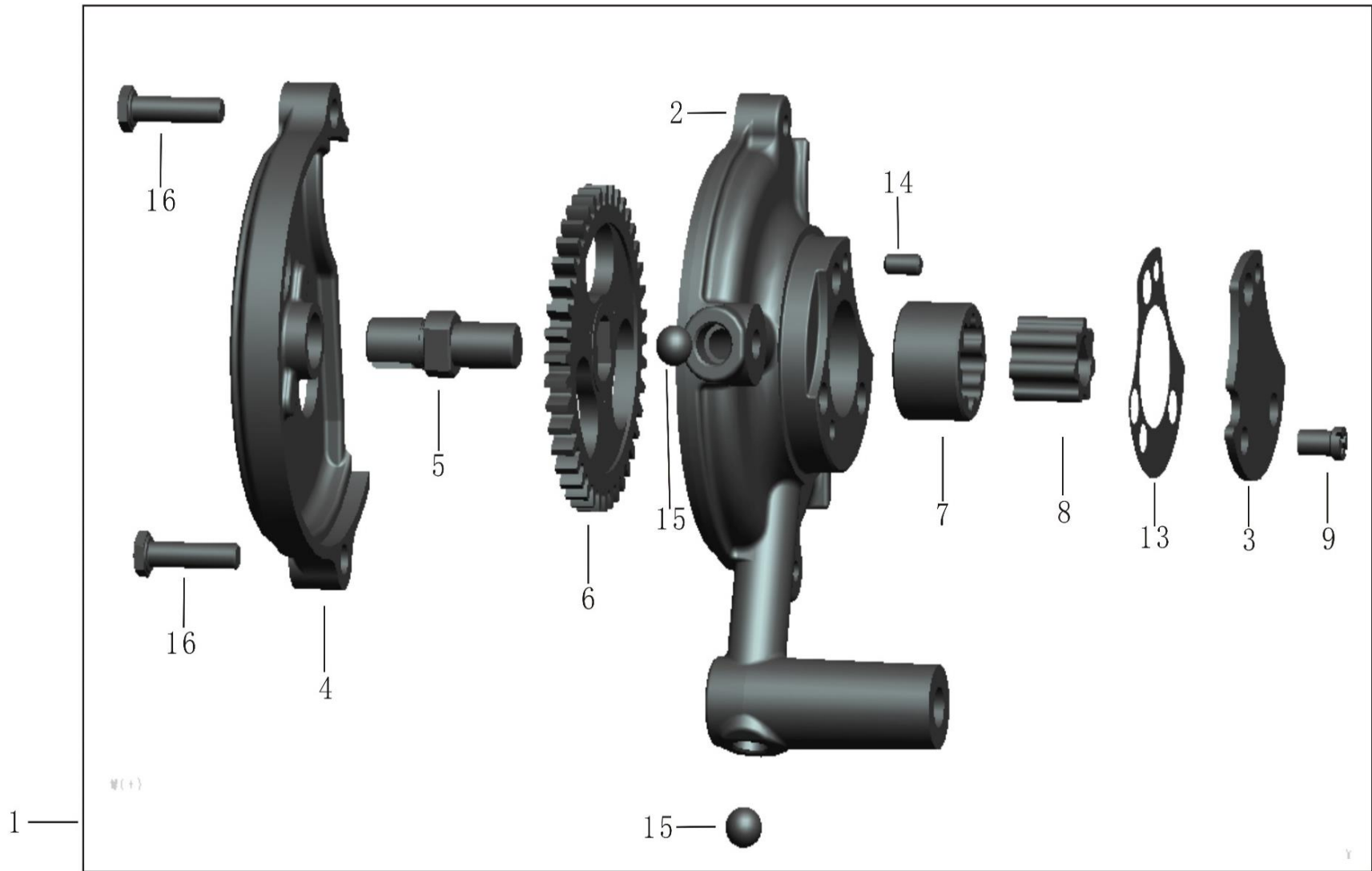

NO	PART CODE	DESCRIPTION	QTY
1	2.23.0106.00000	Pump assy,oil	1

E-7: 离合器总成 (Clutch assembly)

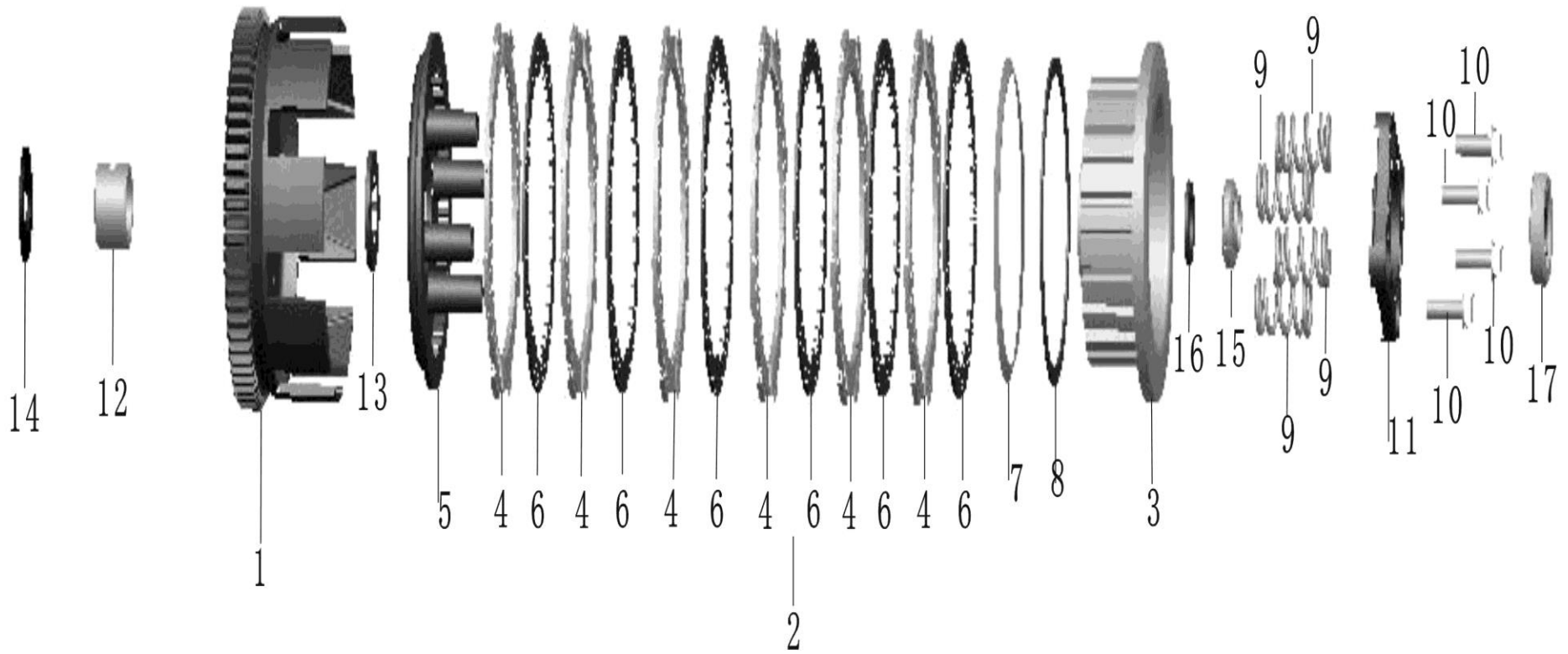

NO	PART CODE	DESCRIPTION	QTY
1	2.20.0107.11000	Outer comp, clutch	1
2	2.20.0107.12000	Center frame comp	1
4	2.20.0107.12210	Disk, clutch friction	6
6	2.20.0107.12400	Plate, clutch	7
14	2.20.0107.00100	Washer	1
15	2.20.0107.00200	Circular nut	1
16	2.20.0107.00300	Washer, thrust	1
17	2.20.0107.20000	Pushing bearing	1

E-8: 左曲轴箱盖总成 (Left crankcase cover assembly)

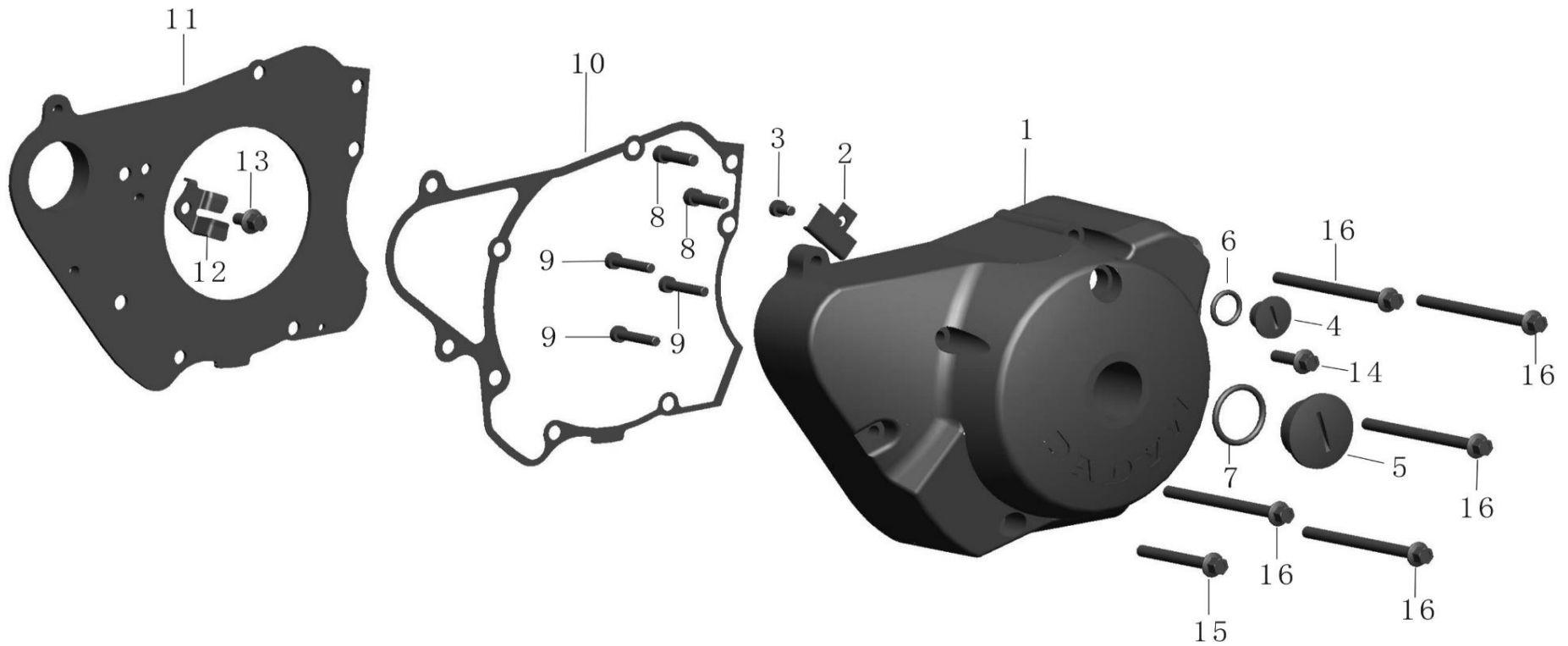

NO	PART CODE	DESCRIPTION	QTY
1	2.20.0108.10108	Cover, left crankcase	1
2	2.20.0108.1020R	Tension Disc	1
3	2.99.03.050080R	Screw, hex M5 x 30-ZnD	1
4	2.20.0108.1030S	Screw M14 x 1.5	1
5	2.20.0108.1040S	Screw M30 x 1.5	1
6	2.20.0108.10500	O-ring 13.8 x 25	1
7	2.20.0108.10600	O-ring 25.8 x 3.1	1
8	2.99.03.060200R	Screw, hex M6 x 20-ZnD	2
9	2.99.03.050250R	Screw, hex M5 x 30-ZnD	3
10	2.20.0108.00110	Gasket, left crankcase cover	1
11	2.20.0108.0020R	Spacer comp, left side	1
12	2.20.0108.00300	Plate, starting sprocket setting	1
13	2.99.26.060100R	Bolt M6 x 10-ZnD	1
14	2.20.0108.0040S	Bolt M6 x 20	1
15	2.20.0112.0020S	Bolt M6 x 50	1
16	2.20.0108.0060S	Bolt M6 x 65	5

E-9: 化油器总成 (双腔) (Carburetor assembly)

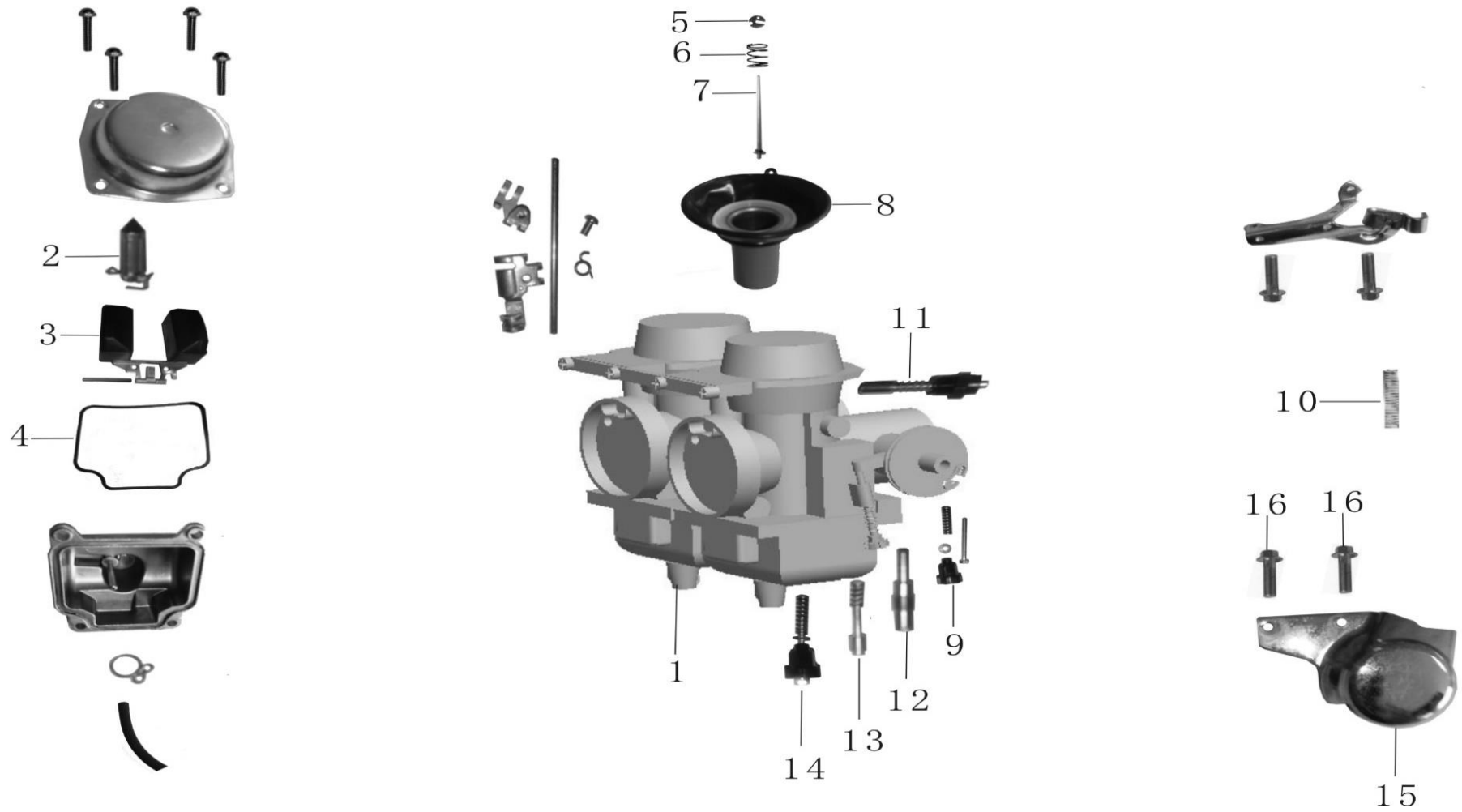

NO	PART CODE	DESCRIPTION	QTY
1	2.20.0109.10010	Carburetor, assy	1
15	2.20.0109.0010S	Decorative cover, carburetor	1

E-10: 电启动总成 (Electricity starting assembly)

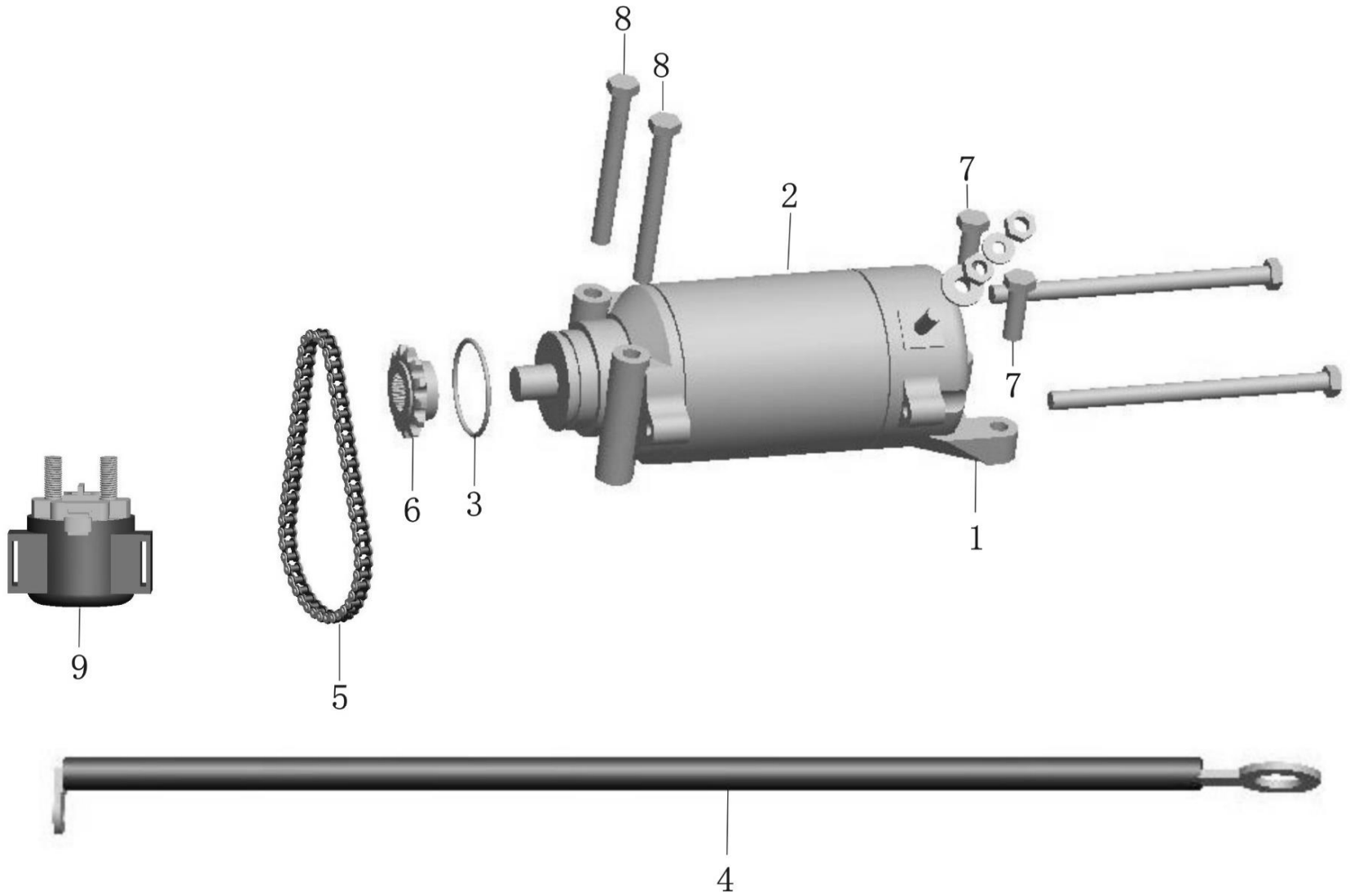

NO	PART CODE	DESCRIPTION	QTY
1	2.20.0110.10000	Starting motor	1
4	2.20.0110.11000	Connecting cable, starting motc	1
5	2.20.0110.30000	Chain, starting	1
6	2.20.0110.10200	Sprocket, starting motor	1
7	2.20.0110.0010S	Bolt M6 x 22	2
8	2.20.0108.0060S	Bolt M6 x 65	2
9	2.20.011020000	Starting relay	1

E-11: 电器系统分总成 (Electrical system)

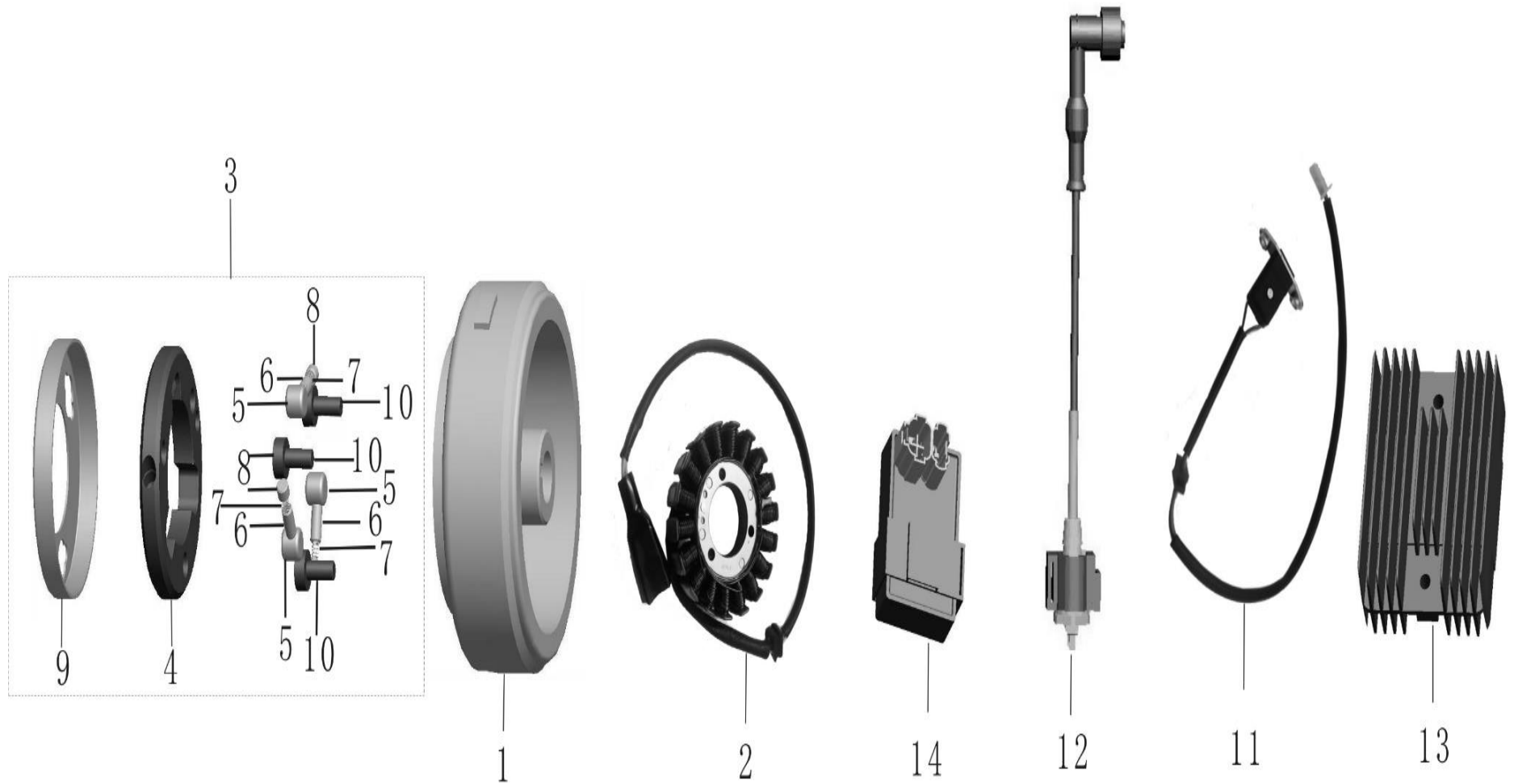

NO	PART CODE	DESCRIPTION	QTY
1	2.23.0111.11000	Flywheel comp	1
2	2.23.0111.12000	Stator comp	1
3	2.22.0111.13000	Starting clutch	1
10	2.20.0111.13700	Screw M8 x 16-ZnD	3
11	2.23.0111.15000	Sensor set	1
12	2.20.0111.30010	Ignition coil	1
13	2.23.0111.40000	Rectifier regulator	1
14	2.23.0111.50000	Igniter	1

E-12: 右曲轴箱盖总成 (Right crankcase cover assembly)

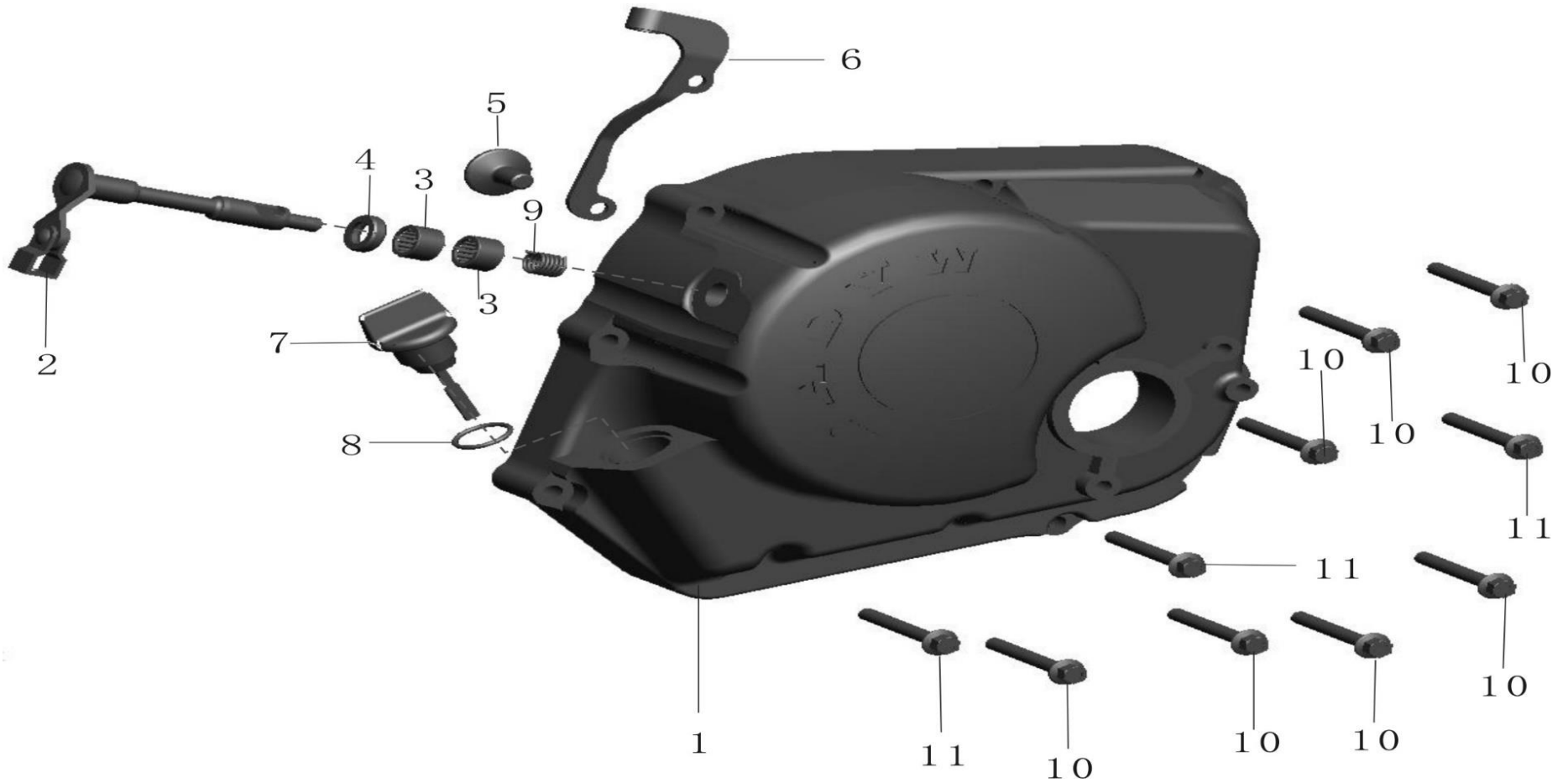

NO	PART CODE	DESCRIPTION	QTY
1	2.23.0112.1010S	Cover comp,right crankcase	1
2	2.20.0112.1100S	Lever comp,clutch	1
3	2.20.0112.12000	Bearing HK1210	2
4	2.20.0112.13000	Oil seal 12 x 18 x 5	1
5	2.20.0112.10200	Pin,clutch lifter	1
6	2.20.0112.1030S	Receiver,clutch cable	1
7	2.20.0112.14000	Gauge,oil level	1
8	2.20.0112.14200	O- ring $\Phi 18 \times 3$	1
9	2.20.0112.10600	Spring S	1
10	2.20.0112.0010S	Bolt M6 x 40	7
11	2.20.0112.0020S	Bolt M6 x 50	3

E-13: 左曲轴箱后盖总成 (Left rear crankcase cover assembly)

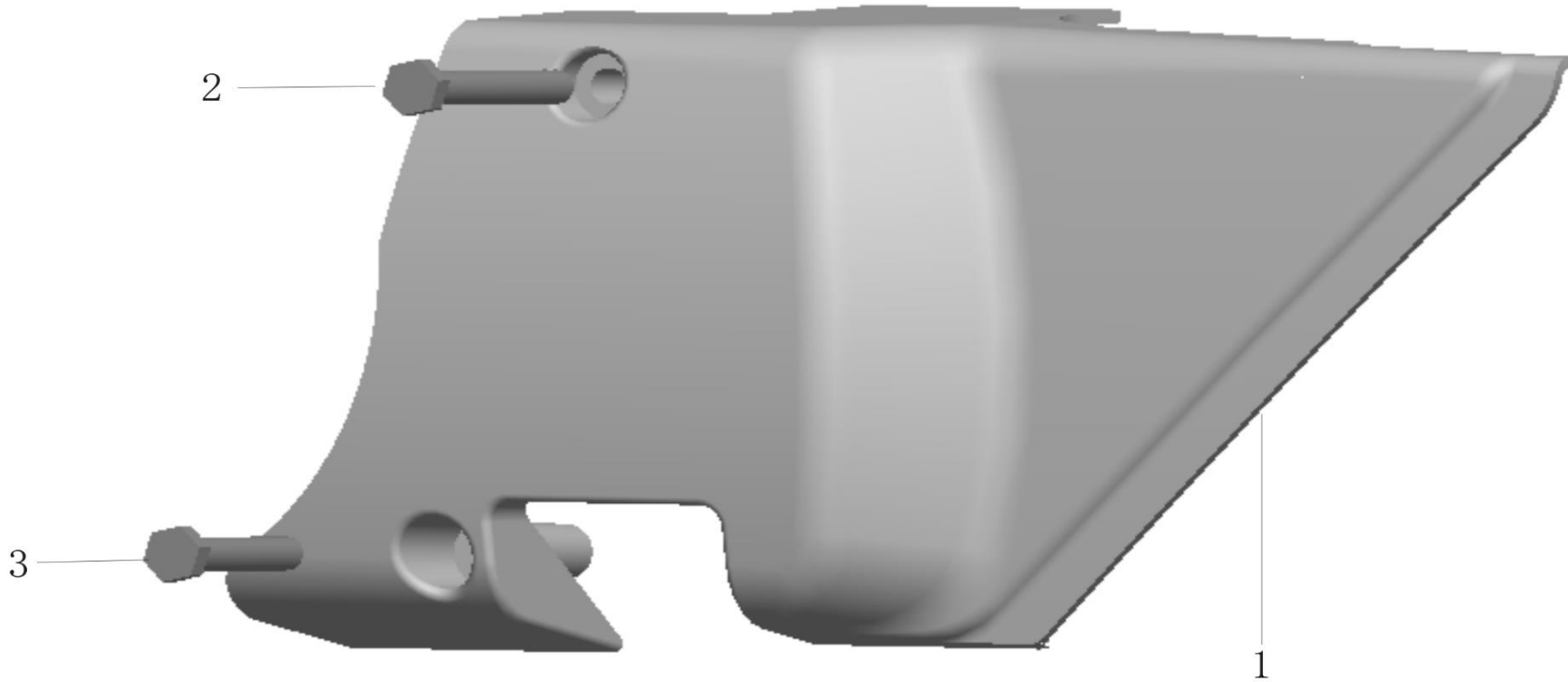

NO	PART CODE	DESCRIPTION	QTY	
1	2.20.0113.1000S	Left rear crankcase	1	
2	2.20.0113.0010S	Bolt M6 x 46	1	
3	2.20.0113.0020S	Bolt M6 x 60	1	

E-13: 左曲轴箱后盖总成 (Left rear crankcase cover assembly) 跑车

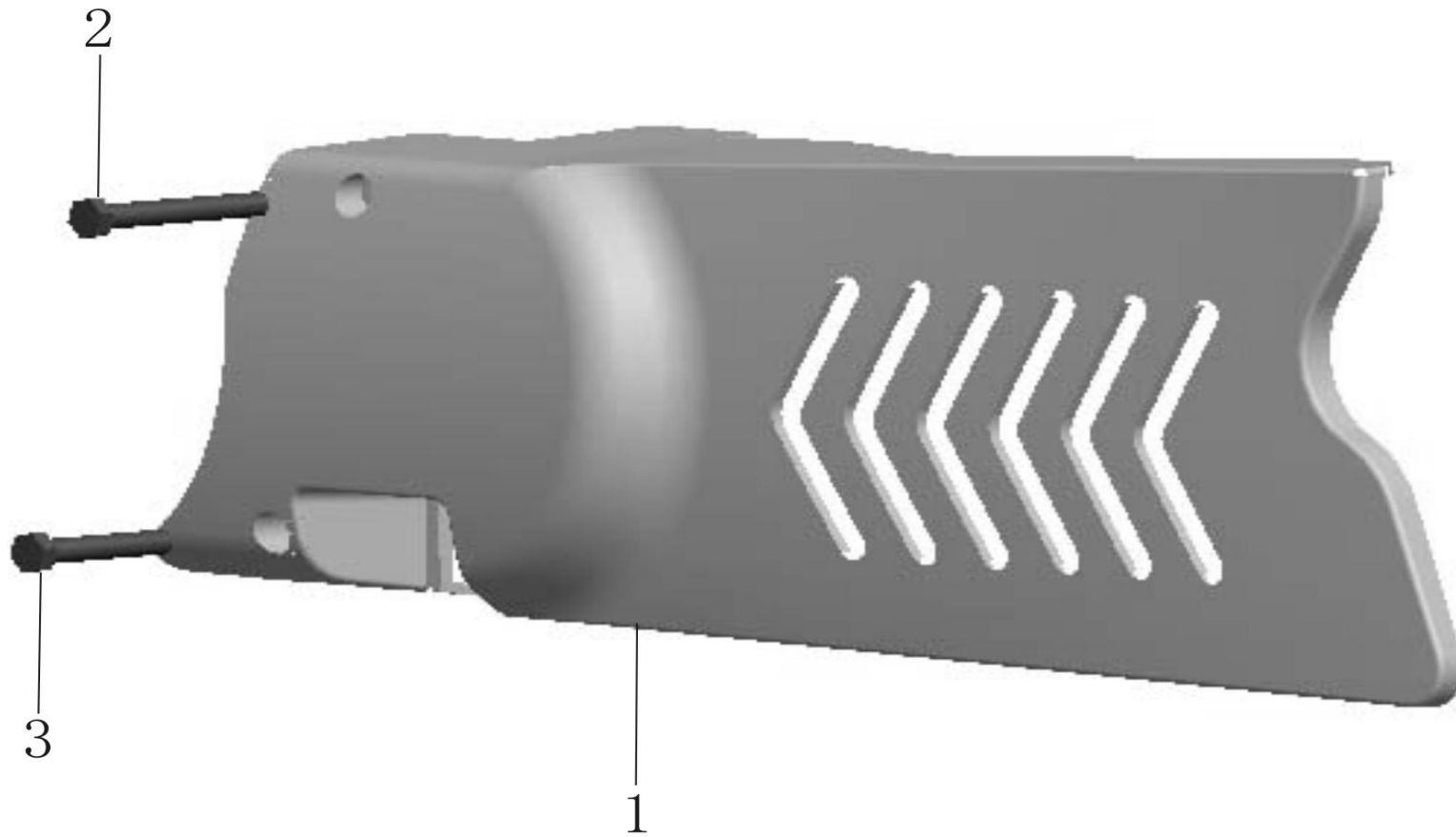

NO	PART CODE	DESCRIPTION	QTY	
1	2.26.0113.1000S	Left rear crankcase	1	
2	2.20.0113.0010S	Bolt M6 x 46	1	
3	2.20.0113.0020S	Bolt M6 x 60	1	

E-14: 变速器总成 (Transmission assembly)

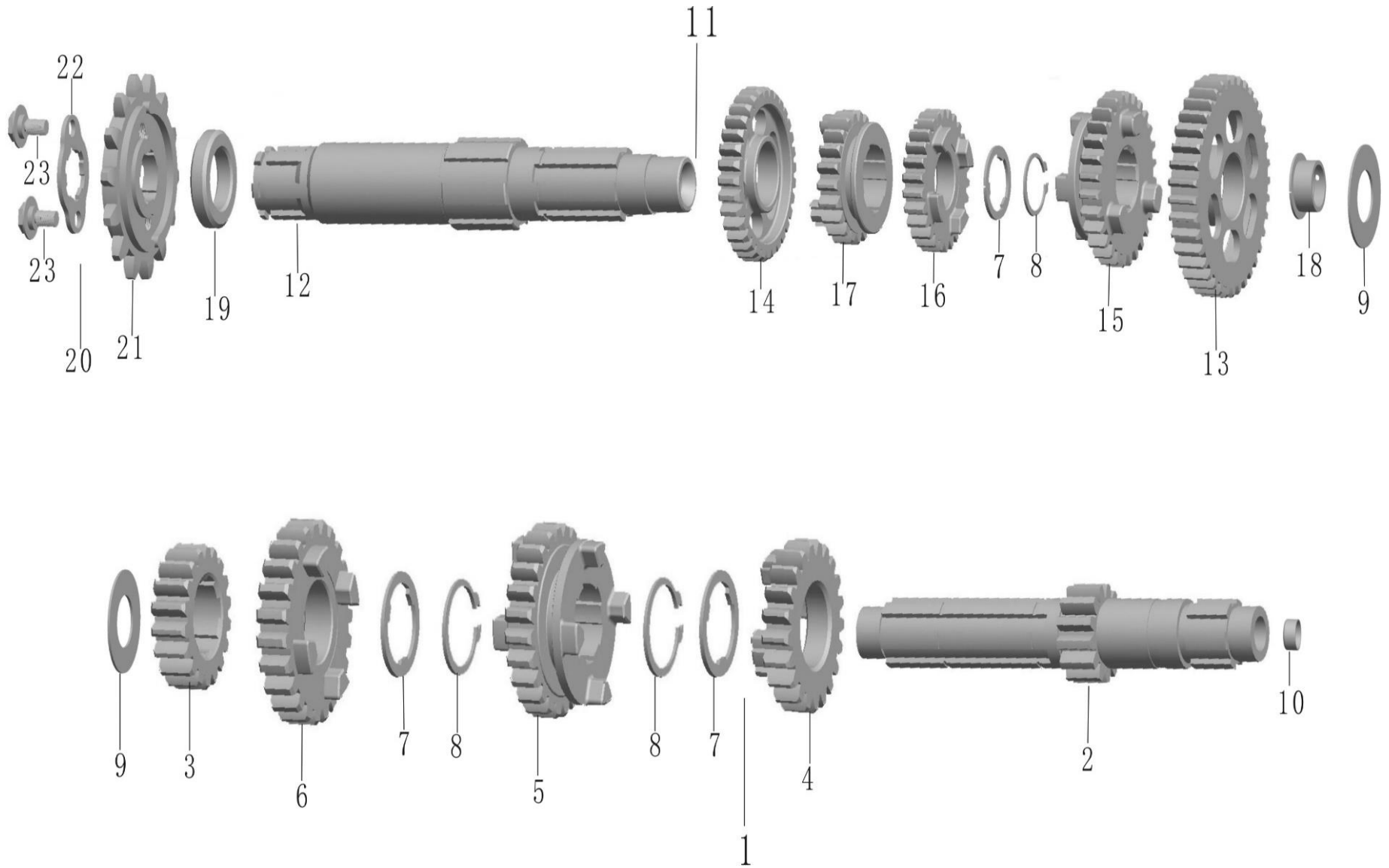

NO	PART CODE	DESCRIPTION	QTY
1	2.20.0114.10000	Main shaft	1
11	2.20.0114.20020	Countershaft	1
12	2.20.0114.20030	Countershaft comp	1
20	2.20.0114.40110	Counter shaft assy	1
22	2.20.0114.40200	Plate,fixing	1
23	2.99.24.060100R	Bolt M6 x 10/ZnD	2

E-14: 变速器总成 (Transmission assembly) 档显)

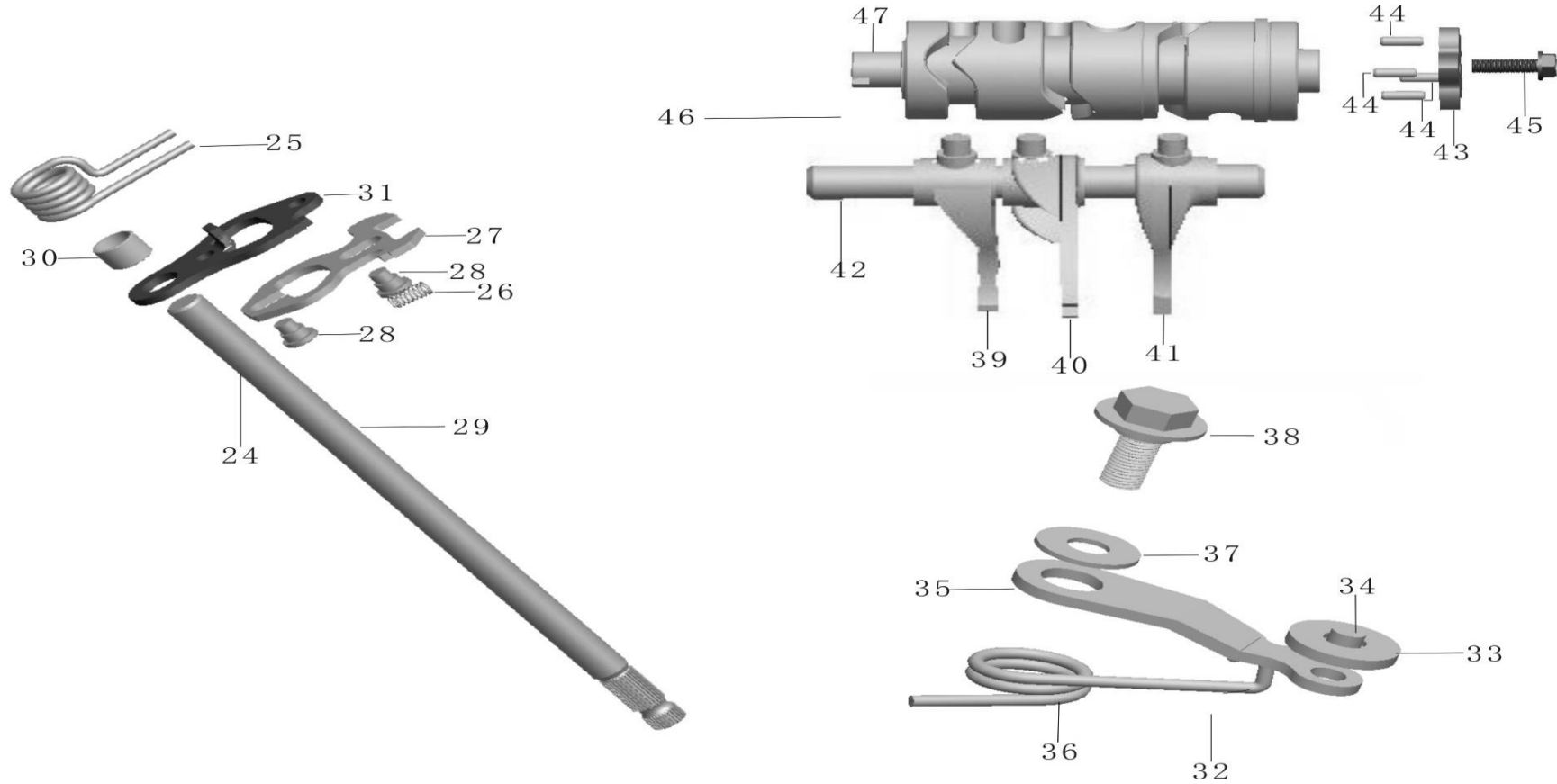

NO	PART CODE	DESCRIPTION	QTY
24	2.25.0114.30000	Spindle comp,gearshift	1
32	2.20.0114.50000	Stopper comp,gearshift drum	1
36	2.20.0114.50100	Spring,shift drum stopper	1
37	2.20.0114.50200	Washer 6	1
38	2.20.0114.5030R	Screw M6 x 12	1
39	2.20.0114.00100	Fork,left gearshift	1
40	2.20.0114.00200	Fork,center gearshift	1
41	2.20.0114.00300	Fork,right gearshift	1
42	2.20.0114.00400	Shaft,gearshift fork guide	1
43	2.20.0114.00500	Plate,drum stopper	1
44	2.20.0114.00600	Pin,gearshift drum	4
45	2.20.0114.0070R	Screw M6 x 20	1
47	2.20.0114.60010	Drum,gearshift	1

E-15: 水泵总成Water pump assembly)-老模具

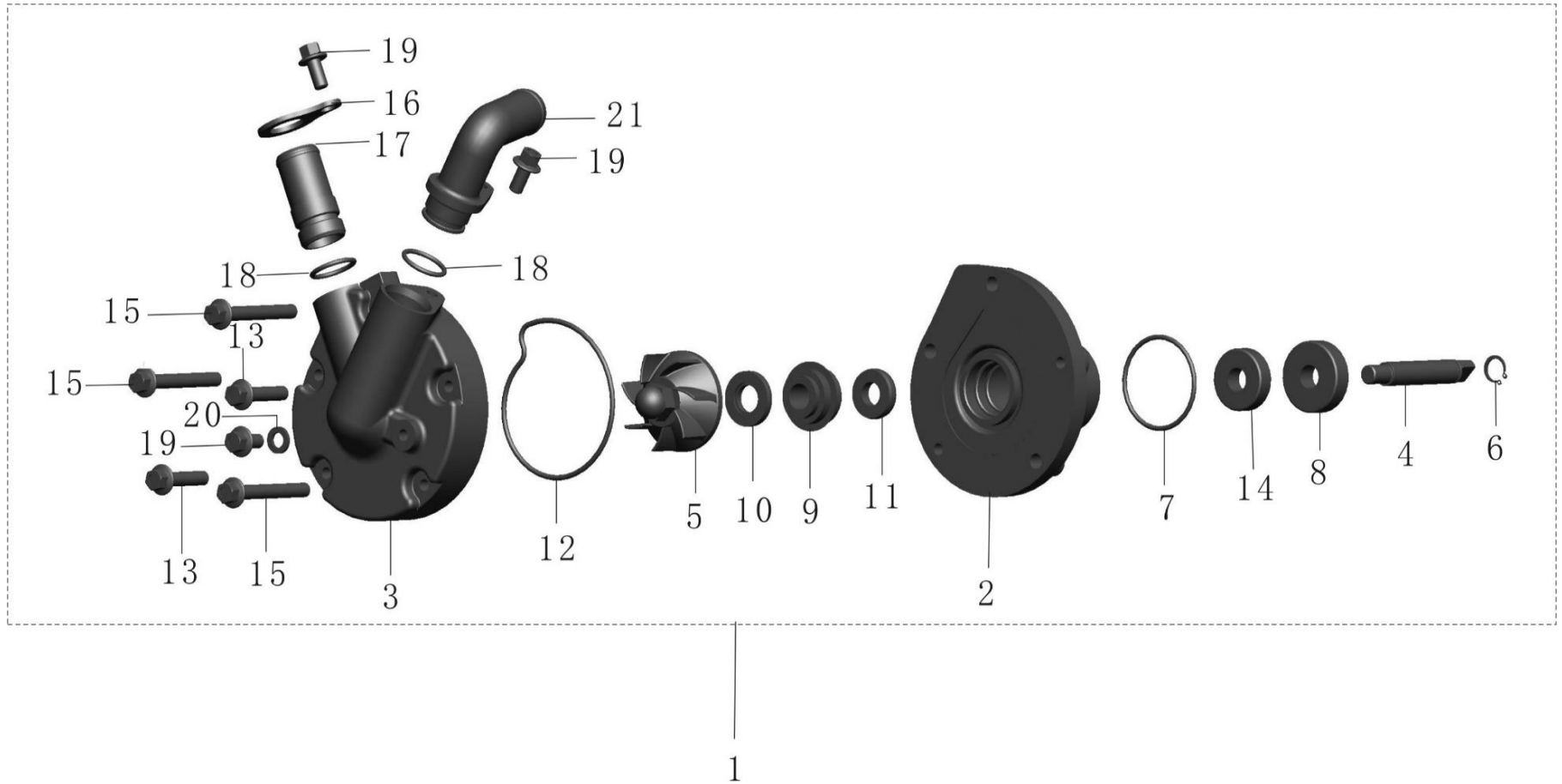

NO	PART CODE	DESCRIPTION	QTY	NO	PART CODE	DESCRIPTION	QTY
1	2.23.0116.00000	Water pump comp	1	12	2.23.0116.00600	O-ring of pump cover	1
2	2.23.0116.0010S	Water pump hull	1	13	2.23.0116.0110S	Bolt M6 x 30	2
3	2.23.0116.0020S	Water pump cover	1	14	2.99.70.0600000	Bearing 6000	1
4	2.23.0116.00300	Water pump shaft	1	15	2.20.0112.0010S	Bolt M6 x 40	3
5	2.23.0116.00402	Fan	1	16	2.23.0101.0240S	Hose connector setting plate	1
6	2.99.63.0800000	Retaining ring 8	1	17	2.23.0101.0250S	Hose connector	1
7	2.23.0116.00500	O-ring φ36 x 2	1	18	2.23.0101.02600	O-ring φ17 x 2	2
8	2.99.70.0620000	Bearing 6200	1	19	2.99.26.060120S	Bolt M6 x 12	3
9	2.23.0116.10000	Water seal A	1	20	2.99.55.0600000	Washer 6	1
10	2.23.0116.20000	Water seal B	1	21	2.23.0116.0120S	Inlet water pump connector	1
11	2.23.0116.30000	Oil seal 21 x 10 x 5	1				

E-15: 水泵总成(Water pump assembly)-新改模具

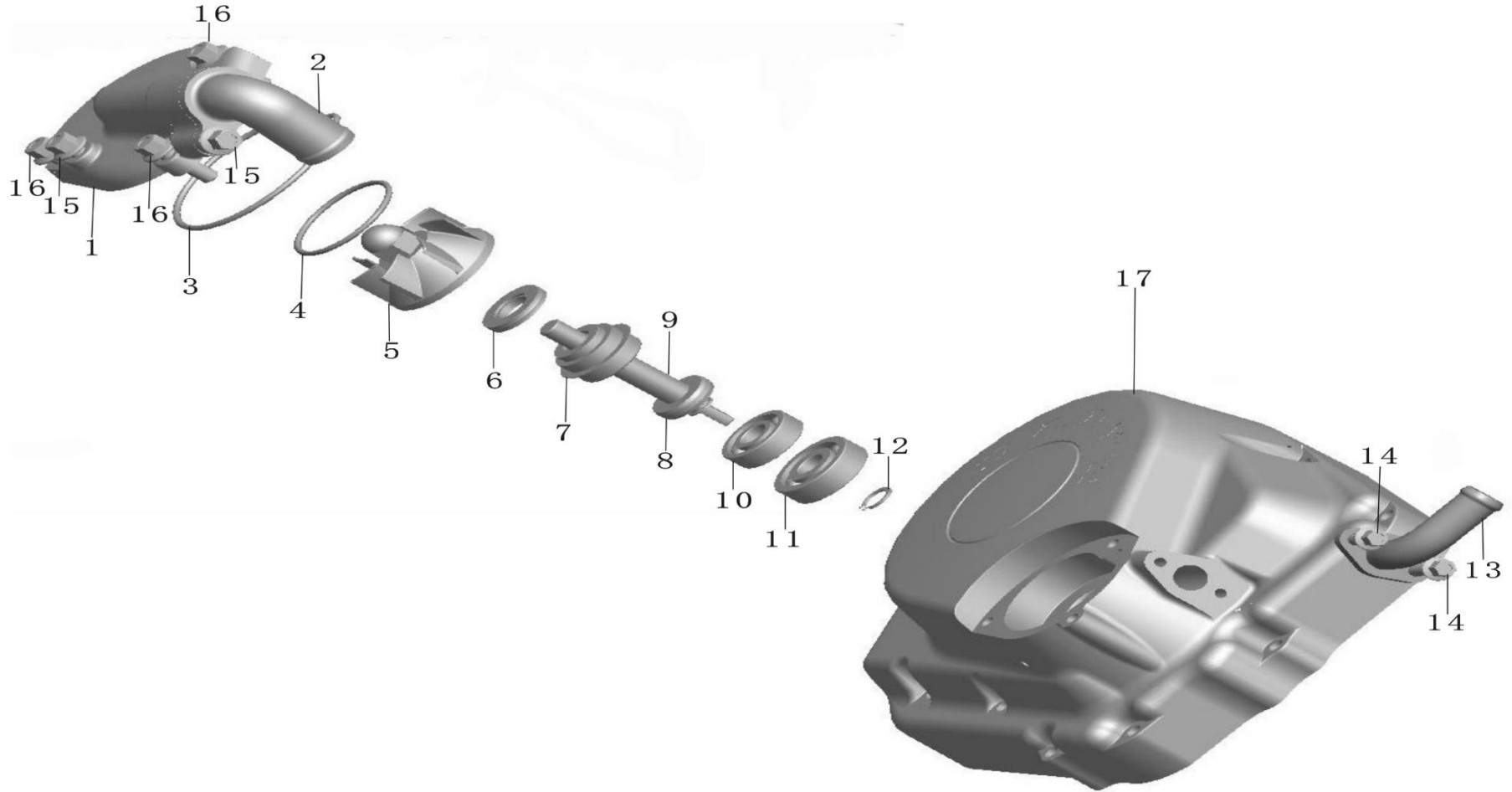

NO	PART CODE	DESCRIPTION	QTY		NO	PART CODE	DESCRIPTION	QTY	
1	2.23.0116.0020S	Water pump cover	1		10	2.99.70.0600000	Bearing 6000	1	
2	2.23.0116.0120S	Inlet water pump connector	1		11	2.99.70.0620000	Bearing 6200	1	
3	2.23.0116.00600	O-ring of pump cover	1		12	2.99.63.0800000	Retaining ring 8	1	
4	2.23.0116.00500	O-ring φ36 x 2	1		13	2.23.0112.1090S	Hose connector	1	
5	2.23.0116.00402	Fan	1		14	2.99.06.060160S	Bolt M6 x 16	2	
6	2.23.0116.20000	Water seal B	1		15	2.99.26.060120S	Bolt M6 x 12	2	
7	2.23.0116.10000	Water seal A	1		16	2.20.0108.0040S	Bolt M6 x 20	3	
8	2.23.0116.30000	Oil seal 21 x 10 x 5	1		17	2.23.0112.10211	Left crankcase cover	1	
9	2.23.0116.00300	Water pump shaft	1						

E-16: 冷却系统(Cooling system)与气缸盖新模具匹配

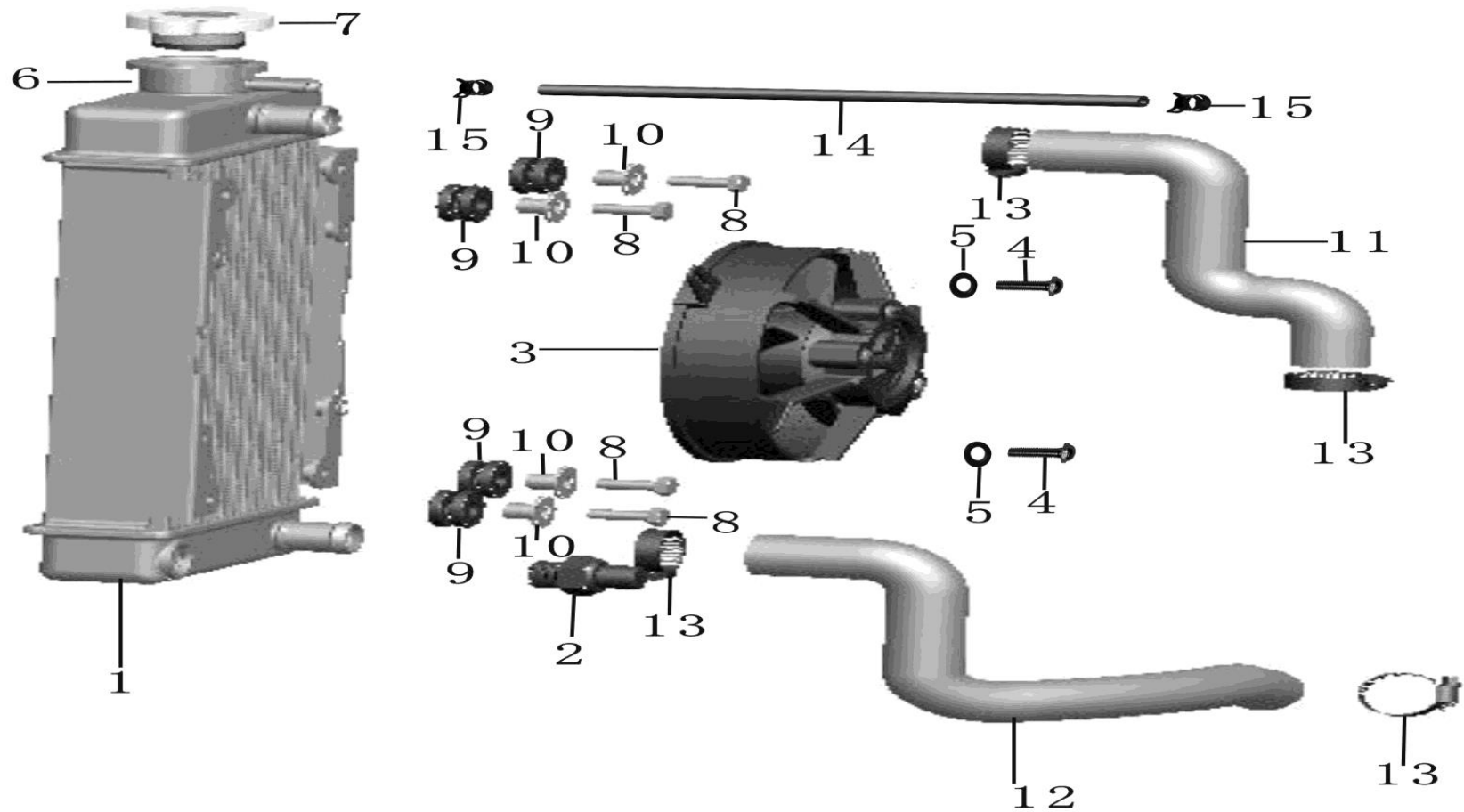

NO	PART CODE	DESCRIPTION	QTY	NO	PART CODE	DESCRIPTION	QTY
1	2.23.0117.11000	Radiator	1	9	2.24.0117.00700	Radiator cushion Washer	4
2	2.23.0117.12000	Fan motor switch	1	10	2.24.0117.00600	Radiator Cushion Washer	4
3	2.23.0117.20000	Fan set	1	11	2.23.0117.00100	Hose of water enter radiator	1
4	2.99.22.050100R	Bolt M5 x 12	2	12	2.23.0117.00200	Hose of water out-flow from	1
5	2.99.54.0500000	Washer 5	2	13	2.23.0117.01000	Tube clip	6
7	2.23.0117.41000	Radiator cap	1	14	2.23.0117.00500	Hose of water enter reservoir	1
8	2.20.0108.0040S	Bolt M6 x 20	4	15	2.23.0117.00300	Hose clip	2

CHASSIS PART

F-1 车架(Chasis)



NO	PART CODE	DESCRIPTION	QTY	NO	PART CODE	DESCRIPTION	QTY
1	1.53.02.011000C	chassis	1	11	1.39.14.1000000	Screw M10*1.25*30	1
2	1.99.26.101120N	bolt M10X112	2	12	1.99.26.0801600	Bolt M8*16	2
3	1.99.44.100000R	Self lock nut M10*1.25	4	13	1.57.02.0400000	mounting plate for E parts	1
4	1.99.26.101320N	bolt M10x1.25x132	1	14	1.57.02.0500000	engine bottom fixture	1
5	1.53.14.0701010	board for left peg	1	15	1.01.02.0500300	Rubber mount	2
6	1.99.02.100250N	Bolt M10*1.5*25	5	16	1.01.02.0500200	Oil seal	2
7	1.53.14.0601010	board for right pedal	1	17	1.01.02.0500500	Washer	2
8	1.63.14.0100000	Side stand w/flameout	1	18	1.01.02.050010C	Short sleeve 14.5mm	2
9	1.01.14.0000300	Side stand spring	1	19	1.01.14.000020N	Bolt M10x1.25x38	1
10	1.51.14.0000200	Bolt M10*1.25*35mm	1	20	1.45.14.0000400	Spare spring (E)II	1

F-2 灯具及主电缆(Lights and Main cable)



NO	PART CODE	DESCRIPTION	QTY	NO	PART CODE	DESCRIPTION	QTY
1	1.57.03.0100300	Headlight bulb 12v35w	1	14	1.45.03.0400100	Turn signal bulb 12V10W(E)	4
2	1.57.15.0100000	Ignition switch set	1	15	1.53.03.0200000	left front turn light set	1
3	1.57.03.0500000	Turn signal R. RR	1	16	1.11.19.000020N	Nut m6	2
4	1.99.42.1000000	Nut M10 X1.5	2	17	1.99.43.060000H	Nut M6	2
5	1.53.03.0520000	rear R turn light bracket	1	18	1.53.03.0400100	front turn light mount	1
6	1.45.03.0600020	Tail light cable	1	19	1.53.03.0300000	right front turn light set	1
7	1.01.03.0900300	Tail light bulb	1	20	1.63.03.0100000	headlight assy	1
8	1.53.03.0410000	rear L turn light bracket	1	21	1.99.56.100000S	Washer spring 10	1
9	1.53.03.0400000	left rear turn light	1	22	1.99.03.100300R	Bolt M10x30	1
10	1.56.32.0901100	reflector	1	23	2.51.0111.80070	flasher	1
11	1.23.04.0700300	single stand flame out switch	1	24	1.66.04.1200000	horn	1
12	1.A7.32.0300000	ECU	1	25	2.51.0111.70030	Diode	1
13	1.53.32.0200000	main cable assy EFI	1				

F-3 蓄电池及蓄电池支架(Battery and Battery bracket)

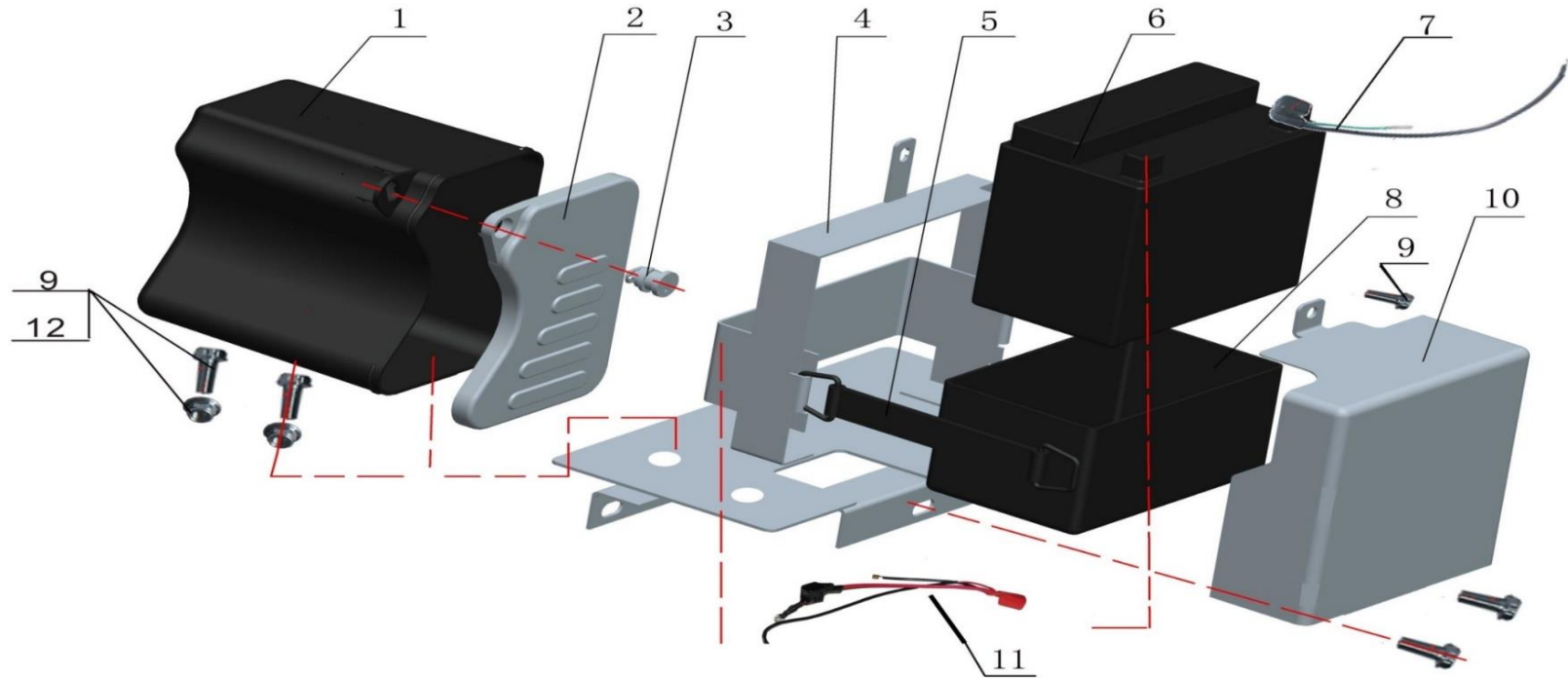

NO	PART CODE	DESCRIPTION	QTY
1	1.57.15.0000100	tool box body	1
2	1.57.15.000020C	tool box cover (matte black)	1
3	1.57.15.000030S	tool box lock	1
4	1.53.02.0300000	battery holder	1
5	1.11.04.0000200	Band,battery	1
6	1.01.04.0300040	Battery 12V9Ah	1
7	1.01.04.1700000	Battery cathode anode	1
8	1.66.04.0400100	Cushion battery	1
9	1.99.27.060120N	bolt M6*12	4
10	1.57.04.001000C	battery cover(BLK)	1
11	1.23.04.0200000	battery positve wire	1
12	1.01.21.0001000	Nut M6	2

F-4 左右开关及操纵总成(Switch.L.R and Guy cable)

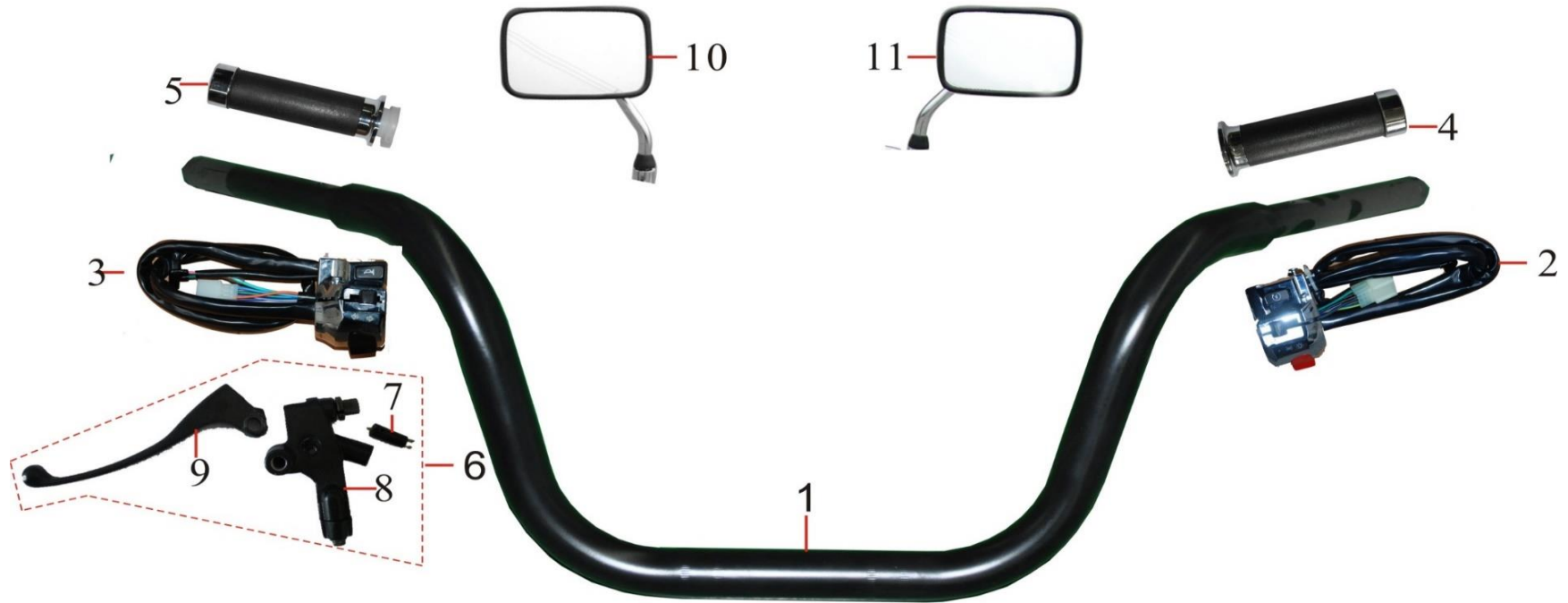

NO	PART CODE	DESCRIPTION	QTY
1	1.53.06.0110000	handle bar	1
2	1.30.06.0250000	Switch L assy.	1
3	1.30.06.0310000	Switch R assy EFI	1
4	1.17.06.0400000	Left grip	1
5	1.17.06.0500900	right grip	1
6	1.25.06.0500000	Clutch control assy.	2
7	1.01.06.0500300	Connector	2
8	1.01.06.0500700	Shake.L	1
9	1.01.06.0500800	Clutch lever	1
10	1.01.06.1300000	Mirror L.RR	1
11	1.01.06.1400000	Mirror R.RR	1

F-4 左右开关及操纵总成(Switch.L.R and Guy cable)

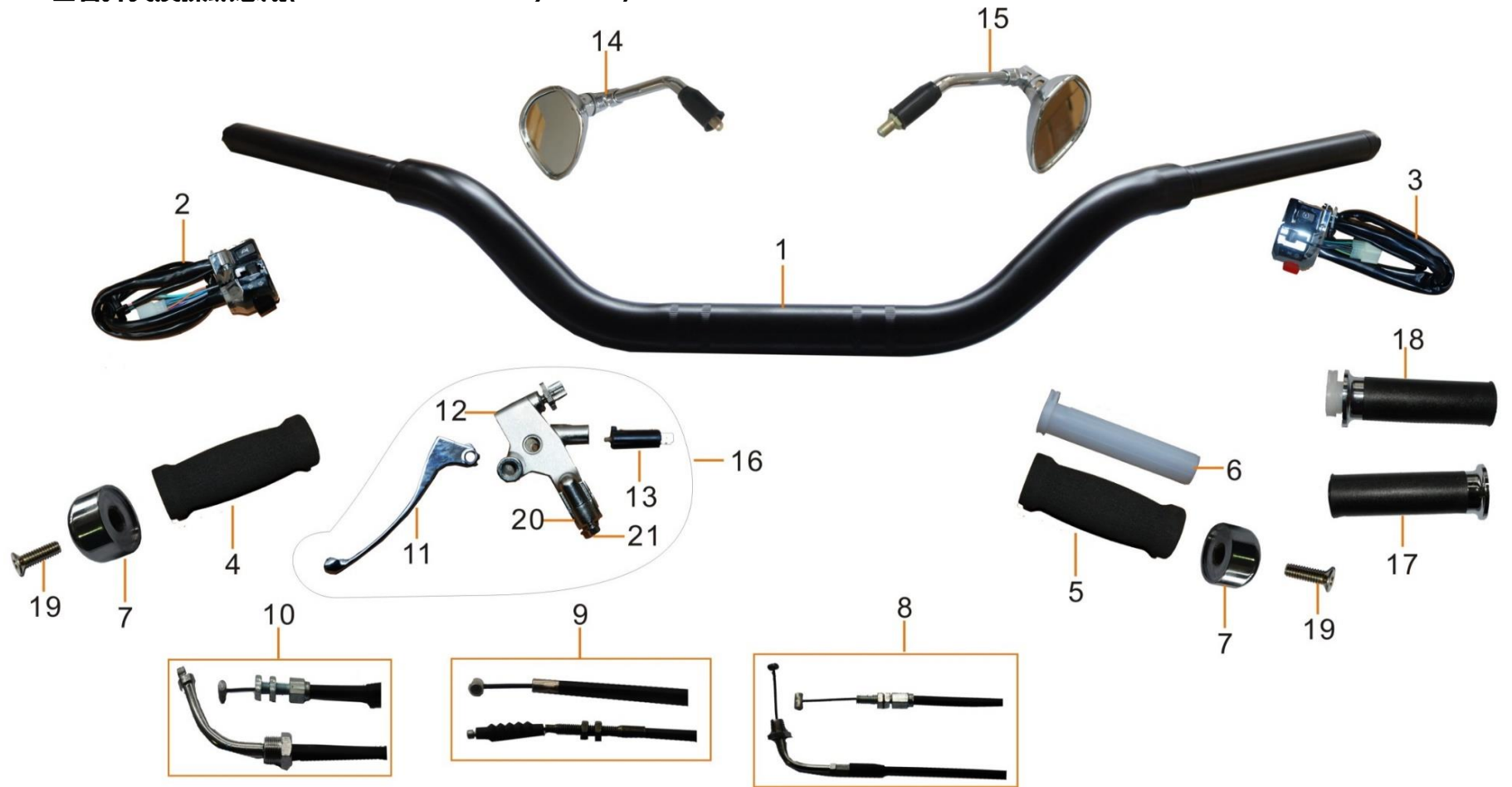

NO	PART CODE	DESCRIPTION	QTY	NO	PART CODE	DESCRIPTION	QTY
1	1.53.06.0100000	handle bar	1	12	1.01.06.0500700	Shake.L	1
2	1.A7.06.0310000	Right switch assy	1	13	1.01.06.0500300	Connector	1
3	1.63.06.0200050	Left switch assy	1	14	1.45.06.1600000	left mirror	1
4	1.57.06.0400000	left grip	1	15	1.45.06.1700000	mirror R.	1
5	1.57.06.0500900	right grip	1	16	1.03.06.0500000	Clutch control assy	1
6	1.57.06.0501000	right grip interior	1	17	1.01.06.0400000	left grip	1
7	1.01.06.0000200	bar balance	2	18	1.01.06.0500900	right grip	1
8	1.53.06.0800000	throttle cable pull	1	19	1.99.06.0602000	Bolt M6*20	2
9	1.53.06.0700200	Clutch cable kit	1	20	1.01.06.0500400	Cover	1
10	1.53.06.1030000	throttle cable(pull)	1	21	1.01.06.0500500	Screw M6*25	2
11	1.01.06.0500800	Clutch lever	1				

F-4 左右开关及操纵总成(Switch.L.R and Guy cable)



NO	PART CODE	DESCRIPTION	QTY
1	1.C6.06.0100000	handle bar (high)	1
2	1.C6.06.0700200	Clutch cable kit	1
3	1.C6.06.0830000	throttle cable pull	1
4	1.30.06.0250010	Switch L assy.	1
5	1.30.06.0350010	Switch R assy	1
6	1.25.06.0500000	Clutch control assy.	1
7	1.17.06.0400000	left grip	1
8	1.17.06.0500000	right grip	1
9	1.01.06.0500300	Connector	1
10	1.01.06.0500700	Shake.L	1
11	1.01.06.0500800	Clutch lever	1

F-5 转向器及里程表(Front shaker frame and Speedometer)

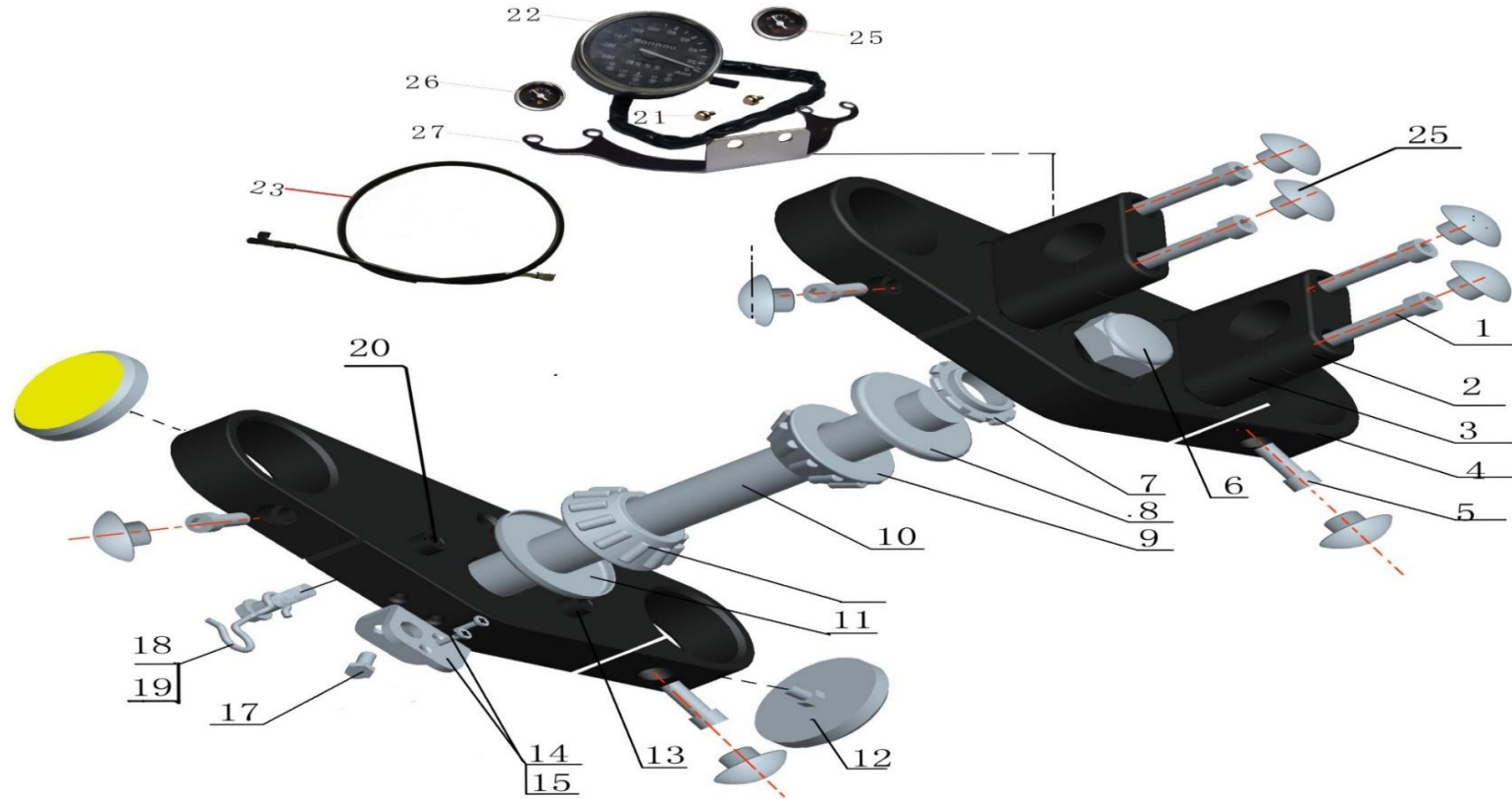

NO	PART CODE	DESCRIPTION	QTY	NO	PART CODE	DESCRIPTION	QTY
1	1.53.06.0000500	hex Bolt inter M8x 80	4	14	1.53.15.0200100	stem lock mount	1
2	1.53.06.000060C	riser cap	2	15	1.99.05.050120N	screw M5X12	2
3	1.53.06.000070C	riser	2	17	1.99.24.060200R	Bolt M6*20	1
4	1.53.06.010010C	top tree (blk)	1	18	1.53.27.0120100	hook	2
5	1.99.03.0802200	hex Bolt M8x22	4	19	1.99.27.080140N	Bolt >flange M8*14	1
6	1.57.07.0000100	Bearings nut M25x1x9.5	1	20	1.53.07.010010C	bottom tree	1
7	1.57.06.0000400	Stem nut M25*1*17	1	21	1.99.24.060120S	Screw M6*12	1
8	1.57.07.0000200	Top cover	1	22	1.53.05.0100030	odometer	2
9	1.99.72.3020500	Bearing 30205	2	23	1.11.05.0100410	speedmeter cable	1
10	1.57.07.0100200	Steering axle	2	24	1.66.06.0000900	top cap button	1
11	1.57.07.0000400	Lower cover	1	25	1.55.05.0600000	fuel gauge	8
12	1.01.07.0500000	Side reflector assy	2	26	1.55.05.0700000	water temp gauge	1
13	1.99.03.0801000	Hex inner bolt M8x10	2	27	1.53.05.0500100	meters bracket	1

F-6 前减震器及前挡泥板 后减震器(Front suspension and Front fender.rear shock absorber)

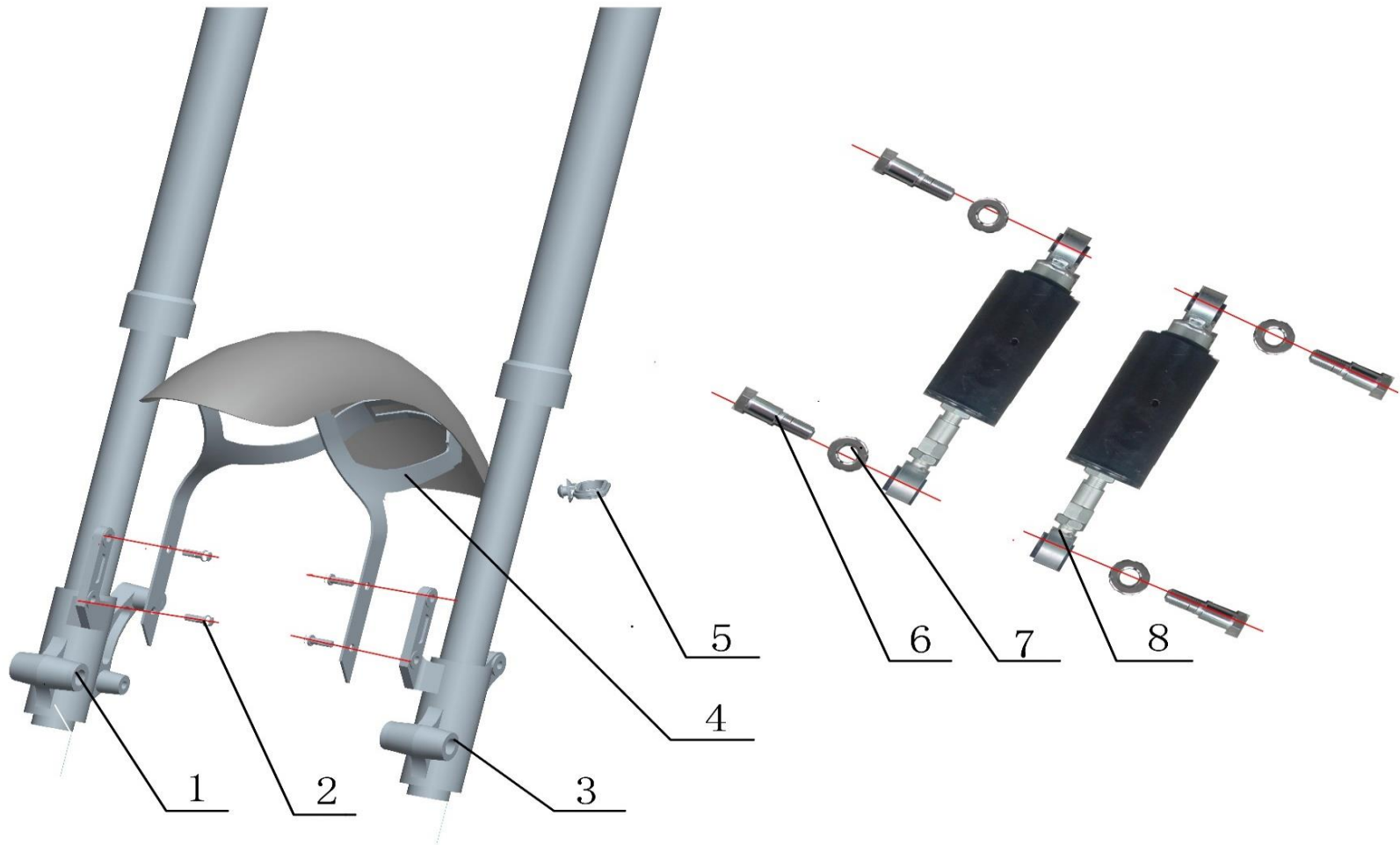

NO	PART CODE	DESCRIPTION	QTY
1	1.C6.07.0400000	complete front brake assembly	1
2	1.99.27.060160S	Bolt M6*16	4
3	1.C6.07.0300000	complete front brake assembly	1
4	1.53.27.000000B	front fender	1
5	1.11.27.0000300	Cable loop	1
6	1.57.20.0000200	rear shock bolt	4
7	1.57.20.000030R	rear shock washer	4
8	1.57.20.0000010	rear shock	2

F-7 前轮(Front wheel)

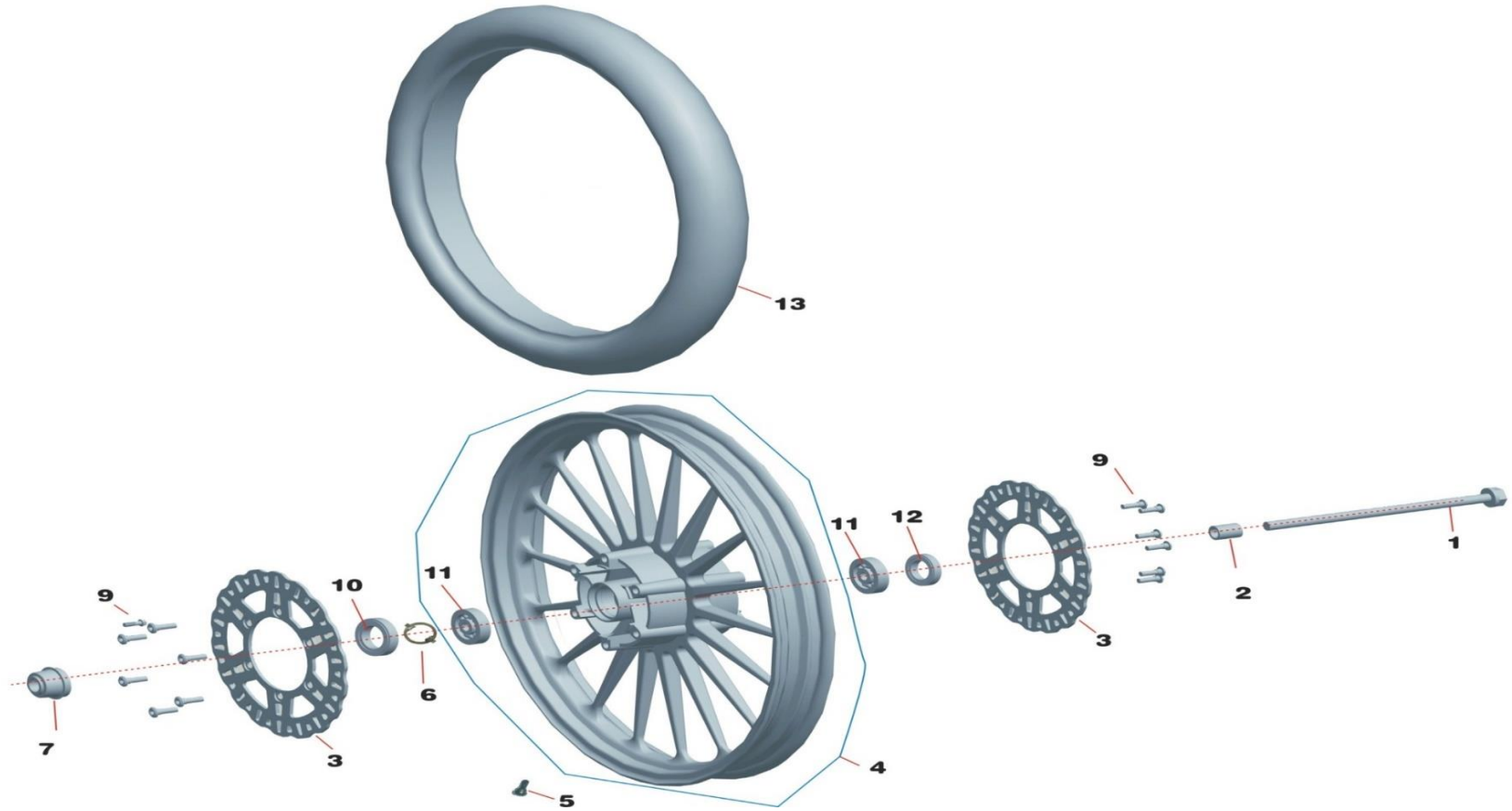

NO	PART CODE	DESCRIPTION	QTY
1	1.C6.08.000010N	complete front brake assembly	1
2	1.C6.08.000400	complete front brake assembly	1
3	1.68.08.0000210	front disc brakeΦ300(Ⅱ)	2
4	1.53.08.010010C	front rim set(21x2.15 black)	1
5	1.01.10.0000500	Valve nut	1
6	1.01.08.0400100	Steering clip	1
7	1.53.08.0400000	speedo drive unit	1
9	1.01.08.000030R	Hex inner bolt M8*24	1
10	1.53.08.0000300	seal 40x55*5	12
11	1.99.72.6303000	bearing 6303-2RZ/Z1	1
12	1.53.10.0000400	Outer oil seal 30x47x5	2
13	1.53.08.0001200	front tire (90/90-21)	1

F-8 前、后制动泵(Front&Rear brake pump assy)

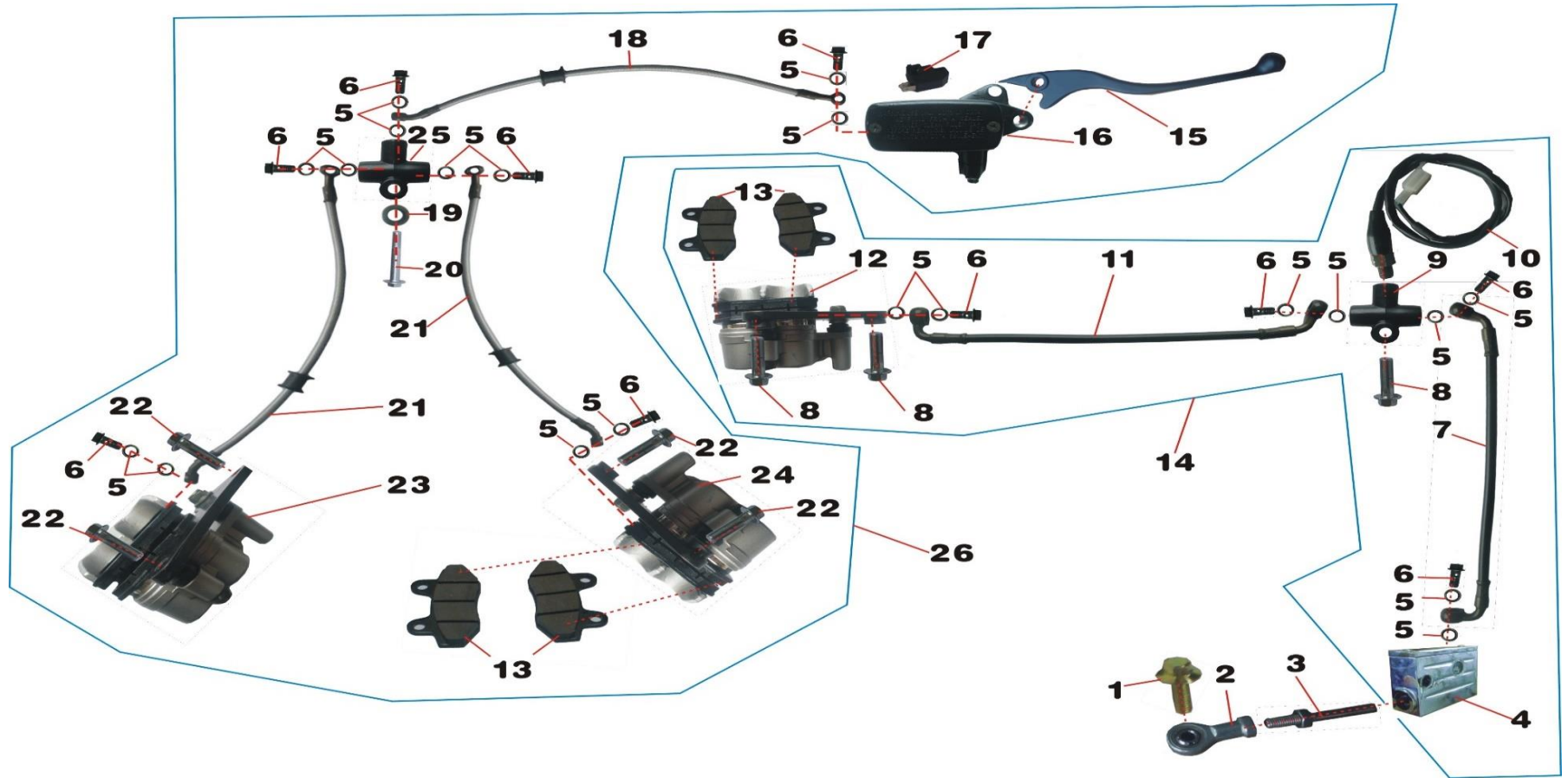

NO	PART CODE	DESCRIPTION	QTY
1	1.99.26.0601600	bolt M6 X 16	1
2	1.57.10.0102000	Chain	1
3	1.57.10.0101000	push pole	1
4	1.57.10.0360000	rear brake pump oil pump	1
10	1.57.10.0330000	rear brake swtich	1
13	1.57.08.0301500	brake pad	6
14	1.65.10.0300000	rear brake pump assy	1
15	1.66.08.0201900	Right clutch lever	1
16	1.57.08.0210000	front brake pump oil pump	1
17	1.01.08.0201700	Brake signal switch	1
25	1.57.08.0260000	front brake three joint	1
26	1.C6.08.0250000	front brake pump assy	1

F-9 后轮(Rear wheel)

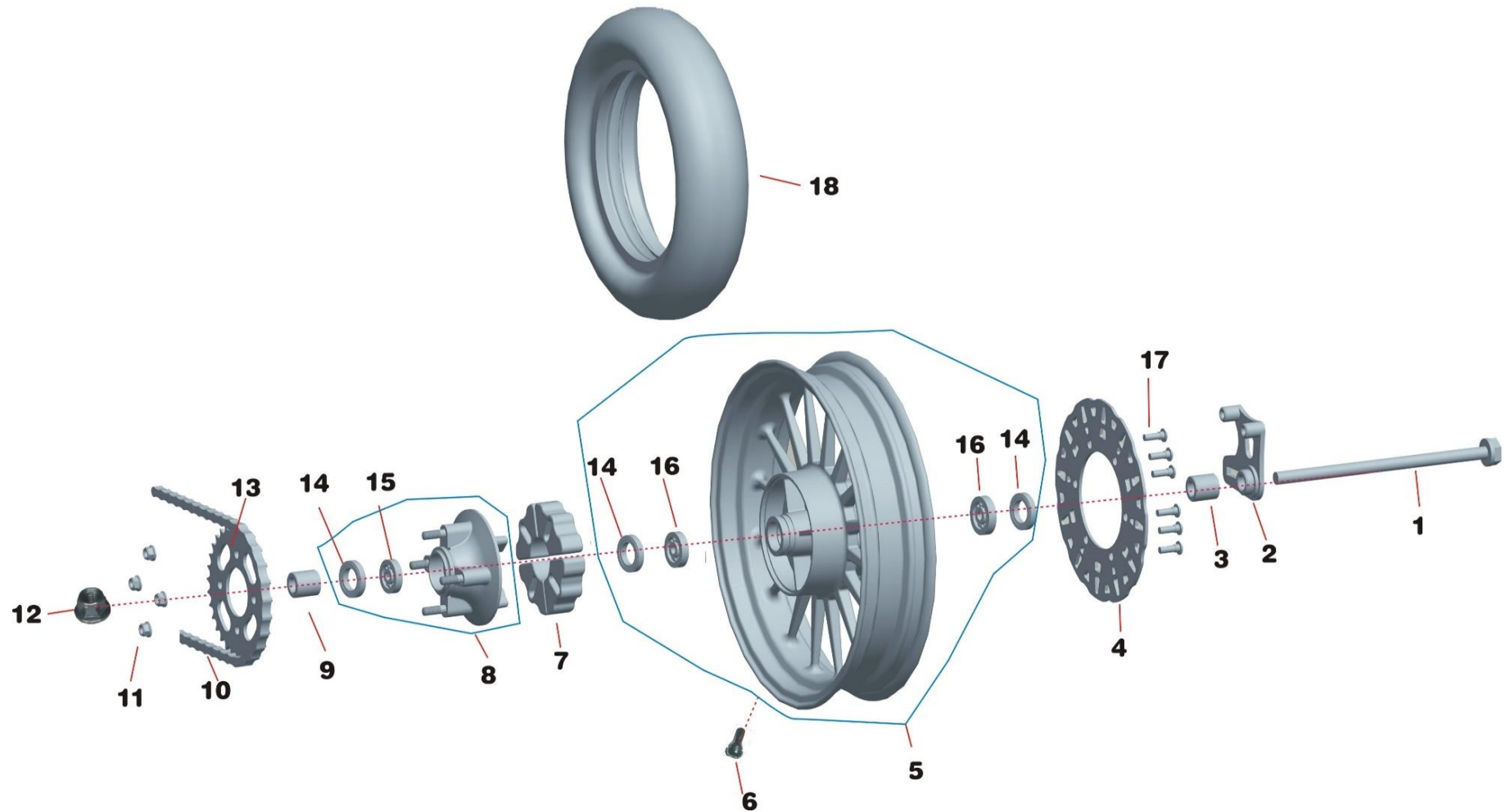

NO	PART CODE	DESCRIPTION	QTY	NO	PART CODE	DESCRIPTION	QTY
1	1.53.10.040000N	Rear wheel axle (14*330mm)	1	10	1.99.79.3002500	chain 530H-1X124L	1
2	1.53.10.0300100	Mount plate.Rear brake pump	1	11	1.99.44.100000R	Self lock nut M10*1.25	4
3	1.30.10.0001400	Alex sleeve R	1	12	1.99.44.140000N	Self locking nut M14*1.5	1
4	1.68.10.0001710	Brake disc.RR 240mm	1	13	1.53.10.0700000	rear sprocket(32T,big hole)	1
5	1.53.10.010000C	rear rim (MT3.75X16,Black)	1	14	1.53.10.0000400	Outer oil seal 30x47x5	3
6	1.01.10.0000500	Valve nut	1	15	1.99.72.6302010	Bearing 6302-2RZ/P6	1
7	1.53.10.0000300	Buffer	4	16	1.99.72.6303000	bearing 6303-2RZ/Z1	2
8	1.53.10.0000600	Cushion buffer set	1	17	1.01.08.000030R	Hex inner bolt M8*24	6
9	1.30.10.0001100	Alex sleeve L	1	18	1.57.10.0001600	rear tire	1

F-10 油箱及燃油开关(Fuel tank and Fuel switch)

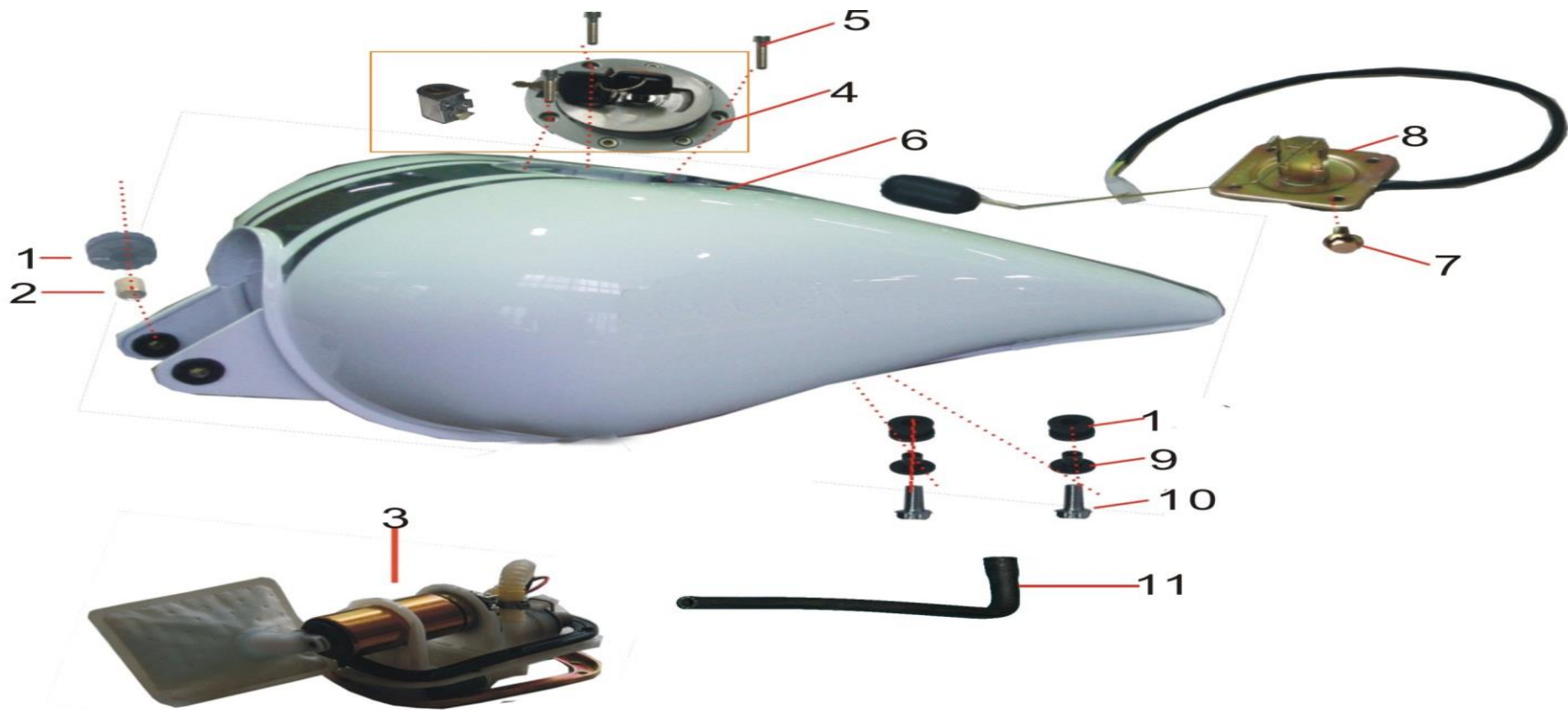

NO	PART CODE	DESCRIPTION	QTY
1	1.11.11.0000100	rubber washer	4
2	1.11.11.0000300	space	2
3	1.03.32.0900000	fuel pump assy	1
4	1.53.15.0000000	Fuel tank lock set	1
5	1.99.03.0502200	hex M5x22	3
6	1.53.11.010000B	fuel tank	1
7	1.99.43.060000H	Nut M6	4
8	1.63.05.0400000	fuel tank sensor	1
9	1.11.11.0000200	fuel tank seal	4
10	1.99.26.0602500	bolt	4
11	1.A7.32.0900200	oil pipe I	2

F-11 座垫及后货架(Seat)



NO	PART CODE	DESCRIPTION	QTY
1	1.63.13.0100000	dual seat	1
2	1.57.13.0000800	dual seat rear mounting bracke	1
3	1.57.13.0100100	Hinge, L.seat	1
4	1.57.13.0100200	Hinge, R.seat	1
5	1.99.43.060000H	Nut M6	6
6	1.99.27.100150S	Bolt M10x1.5x15	2
7	1.99.27.060120S	Bolt M6*12	1
8	1.99.44.060000N	bolt M6	1

F-12 变速机构及换档机构(Shift gear System and shifter)

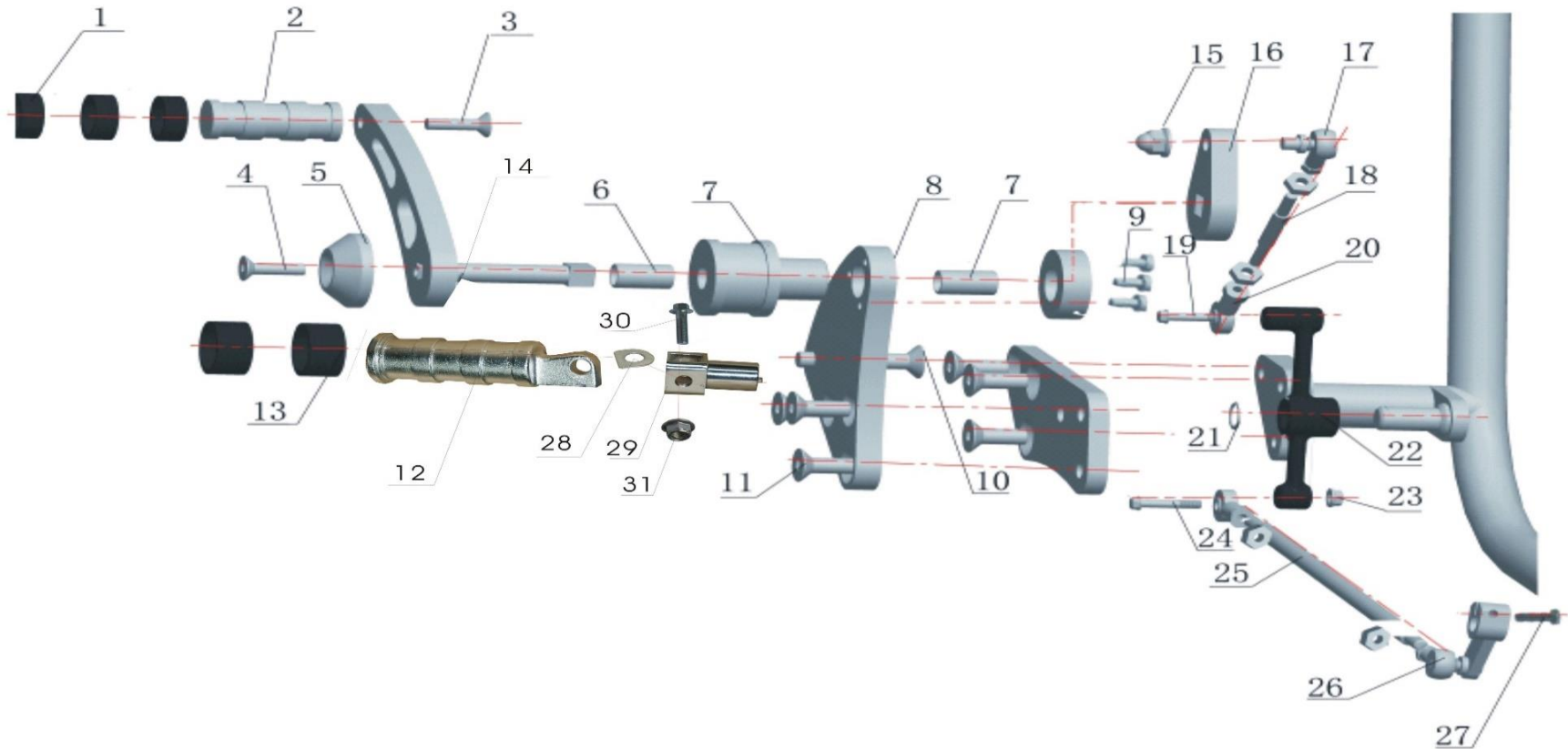

NO	PART CODE	DESCRIPTION	QTY	NO	PART CODE	DESCRIPTION	QTY
1	1.57.14.0240400	Rubber sleeve	3	16	1.53.14.0600600	shifter pole II	1
2	1.63.14.0240100	Peg pole (CP)	1	17	1.63.14.0600800	Front joint	1
3	1.99.02.0802500	Hex inner bolt M8*25	1	18	1.30.14.0600700	Two end screw	1
4	1.99.02.060160S	Hex bolt M6*16	1	19	1.01.06.0500500	Screw M6*25	1
5	1.57.14.0600100	Connector L	1	20	1.57.10.0102000	Chain	2
6	1.57.14.0610200	Alex sleeve (small)	1	21	1.99.63.1500000	flexible ring	1
7	1.57.14.0610100	Mounting bracket. L (CP)	1	22	1.53.14.0600600	shifter pole II	1
8	1.57.14.060040S	Mounting plate. L	1	23	1.99.44.060000S	Self-locking nut M6	1
9	1.99.03.0601600	Hex bolt interM8*10	3	24	1.99.26.0603500	Bolt M6x35	1
10	1.99.02.1004500	Hex inner bolt M10*1.5*45	1	25	1.02.14.0600600	Two end bolt 245mm	1
11	1.99.02.100250N	Bolt M10*1.5*25	6	26	1.17.14.0800000	Shake lever assy	1
12	1.57.14.0250200	left peg (folded)	1	27	1.99.24.0602000	Bolt M6*20	1
13	1.57.14.0230300	Rubber sleeve(II)	3	28	1.57.14.0250400	flexible washer	1
14	1.57.14.0600200	Shift pole (I)	1	29	1.57.14.0250100	peg mount	1
15	1.01.03.0101300	cap Nut M8	1	30	1.01.21.0001100	Bolt M10*40	1

F-13 后制动机构(Rear brake pole)

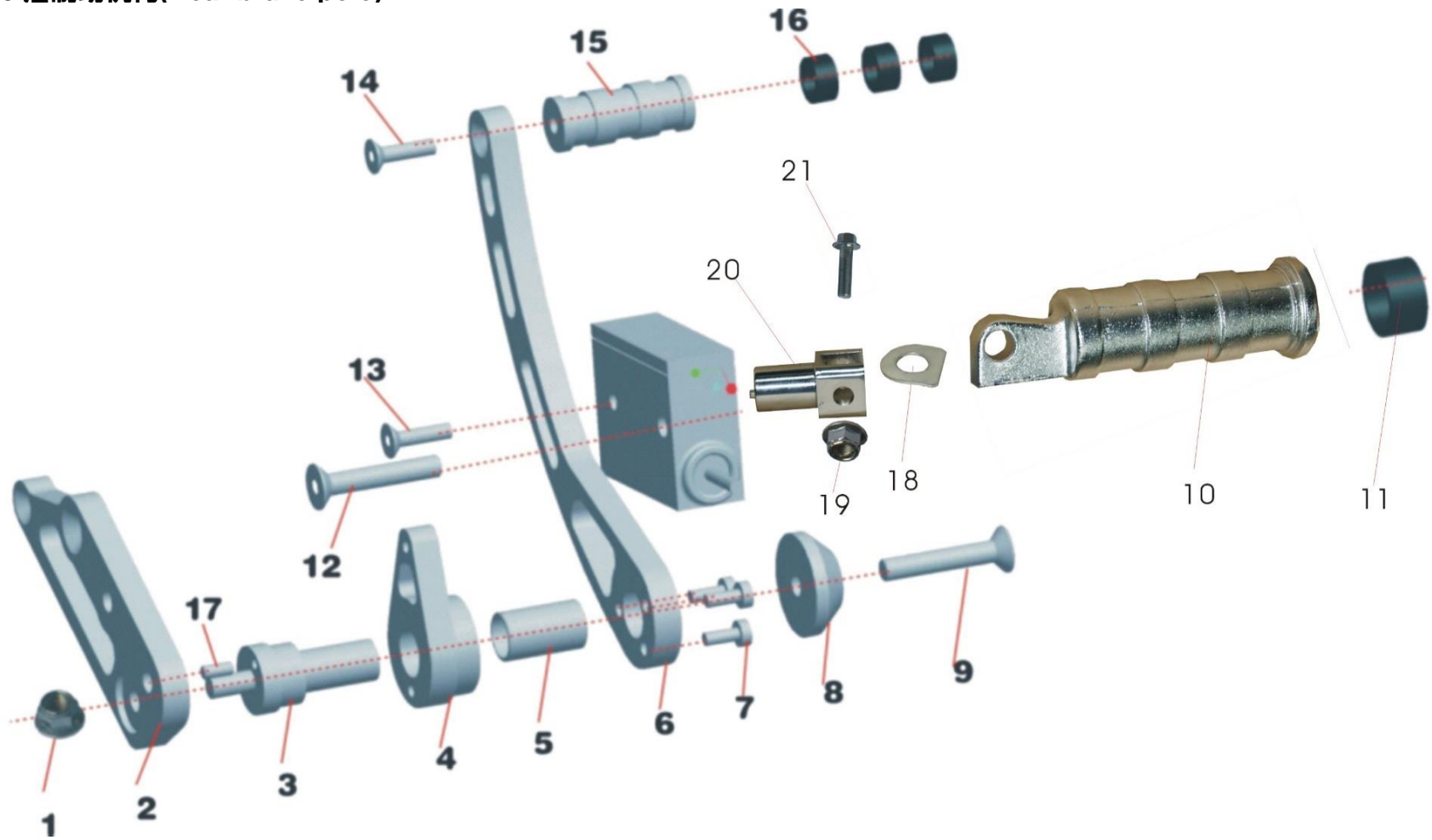

NO	PART CODE	DESCRIPTION	QTY	NO	PART CODE	DESCRIPTION	QTY
1	1.99.44.100000R	Self lock nut M10*1.25	1	12	1.99.02.1006500	Bolt M10*1.5*65	1
2	1.57.14.020010S	Mounting bracket. R (CP)	1	13	1.99.02.0803500	Hex inner bolt M8*35	1
3	1.57.14.0200000	Control spacer	1	14	1.99.02.0802500	Hex inner bolt M8*25	1
4	1.57.14.0220000	Pole bracket. Rear brake	1	15	1.63.14.0240100	Peg pole (CP)	1
5	1.57.14.0220200	Spacer (big)	1	16	1.57.14.0240300	Rubber sleeve(IV)	3
6	1.57.14.0200200	Rear brake pole	1	17	1.57.14.0220300	Pin	1
7	1.99.03.0601600	Hex bolt interM8*10	3	18	1.57.14.0250400	flexible washer	1
8	1.57.14.0200300	right connect CP	1	19	1.99.44.100000R	Self lock nut M10*1.25	1
9	1.99.02.1003500	Hex inner bolt M10*1.5*35	1	20	1.57.14.0250100	peg mount	1
10	1.57.14.0250300	right peg (folded)	1	21	1.01.21.0001100	Bolt M10*40	1
11	1.57.14.0240400	Rubber sleeve	3				

F-14 空滤器总成(Air filter assy)

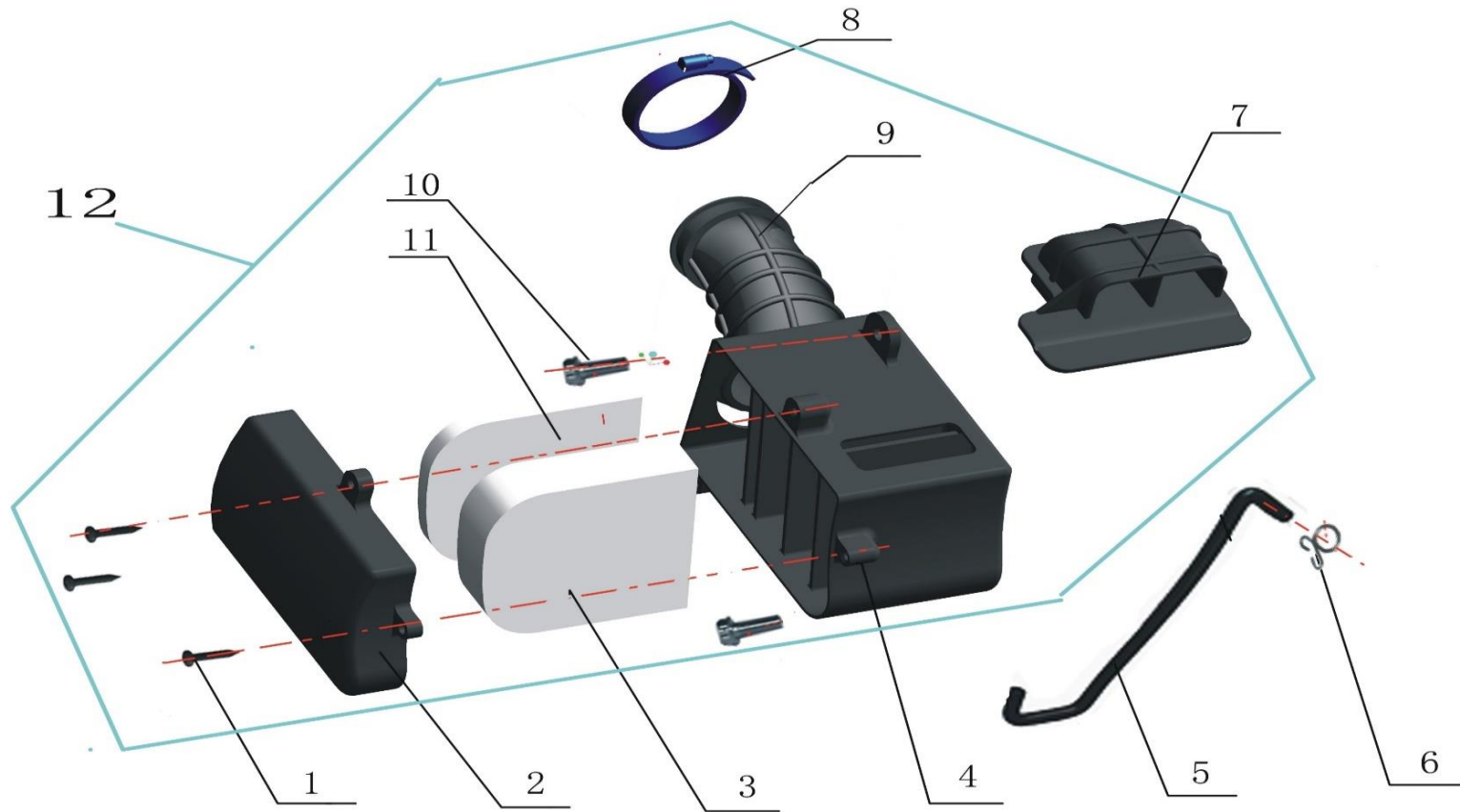

NO	PART CODE	DESCRIPTION	QTY
1	1.99.15.4202400	Self-tapping screwST4.2*24	3
2	1.63.17.0001300	Air filter upper shell	1
3	1.63.17.0001100	Air filter core	1
4	1.63.17.0001400	Air filter bottom shell	1
5	1.63.17.0000500	circuit pipe	1
6	1.01.17.0000900	Tight wreath of steel wire flexib	1
7	1.A7.17.0000200	air filter outlet pipe	1
8	1.01.17.0000100	Hoop	1
9	1.01.17.0001000	The air filter enters the draft	1
10	1.99.26.060120H	螺栓M6×12	2
11	1.63.17.0001200	Screen,filter	1
12	1.A7.17.0000000	air filter assy	1

F-15 排气消声器(Exhaust-gas muffler)

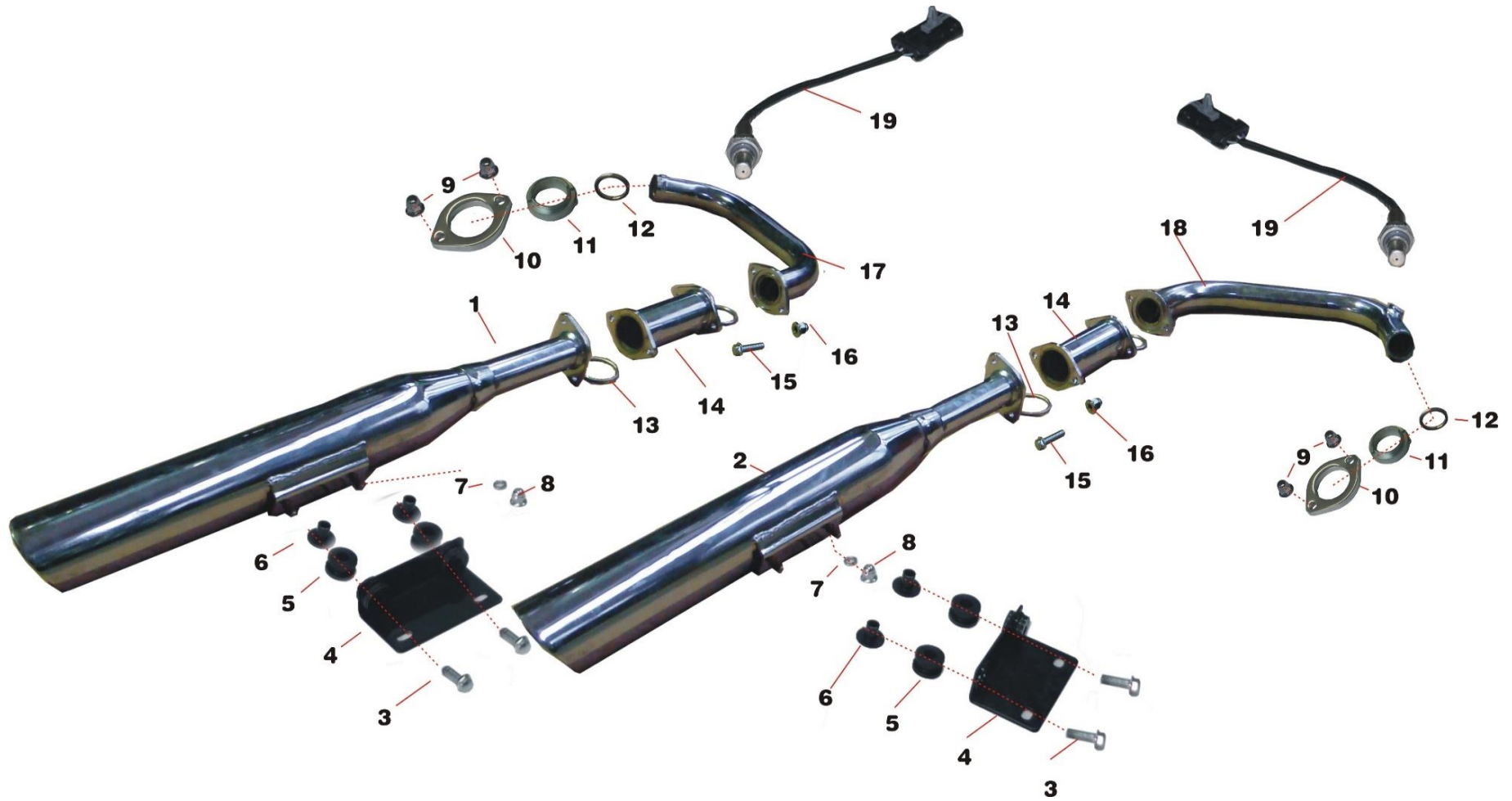

NO	PART CODE	DESCRIPTION	QTY	NO	PART CODE	DESCRIPTION	QTY
1	1.63.18.0100200	left rear exhaust	1	11	1.01.18.0300000	tube ends	2
2	1.63.18.0200200	right rear exhaust pipe	1	12	1.01.18.0000210	Seal washer.	2
3	1.99.24.0802500	Hex bolt inter M8*40	4	13	1.10.18.0300200	seal washer $\Phi 43 \times \Phi 52$	4
4	1.57.18.0500000	Exhaust mount L	2	14	1.10.18.0310000	exhaust pipe joint	2
5	1.01.18.0000600	Mat block	4	15	1.99.26.0602200	Screw M6*22	8
6	1.01.18.0000700	Short spacer (BK)	4	16	1.99.44.060000S	Self-locking nut M6	8
7	1.99.56.080000S	Spring washer t8	4	17	1.63.18.0100110	exhaust pipe	1
8	1.99.42.0800000	Nut M8(stainless)	4	18	1.63.18.0200110	exhaust pipe	1
9	1.01.18.000030S	Nut M8	4	19	1.A7.32.0600000	oxygen sensor	2
10	1.01.18.0000100	Exhaust flange	2				

F-15 排气消声器(Exhaust-gas muffler)

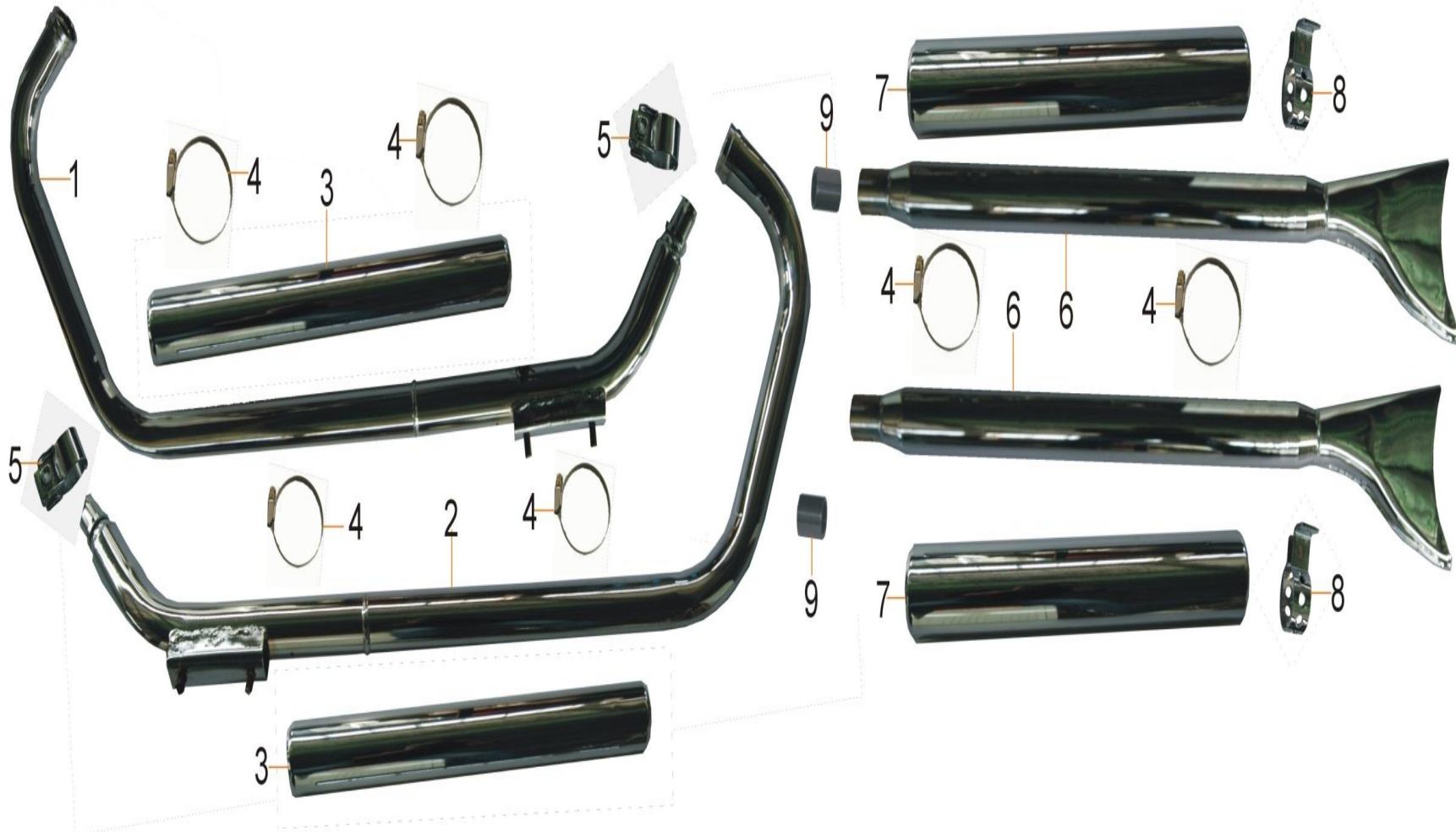

NO	PART CODE	DESCRIPTION	QTY
1	1.B5.18.010000S	L exhaust pipe EFI	1
2	1.B5.18.020000S	R exhaust pipe EFI	1
3	1.B5.18.0300000	exhaust front cover	2
4	1.01.17.0000100	hoop	8
5	1.01.18.000090S	clip hoop	2
6	1.B5.18.0400000	rear muffler	2
7	1.B5.18.0500000	exhaust rear cover	2
8	1.B5.18.0500100	exhaust mounting hoop	2
9	1.01.18.0000500	sleeve	2

F-16 后轮罩(Rear fender)

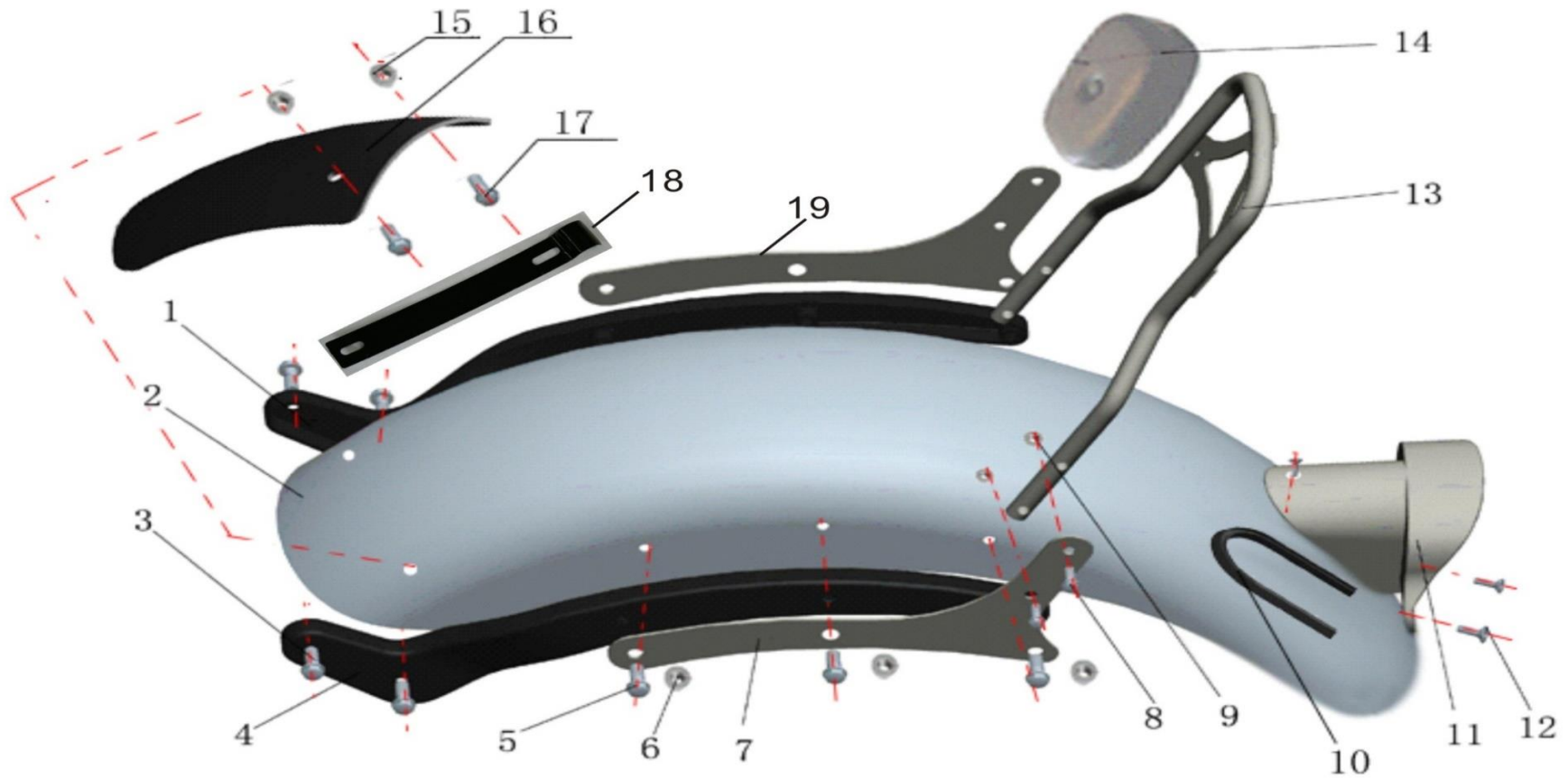

NO	PART CODE	DESCRIPTION	QTY		NO	PART CODE	DESCRIPTION	QTY	
1	1.53.21.000080C	Rear fender supports stand R B	1		11	1.53.21.0002200	rail light bracket	1	
2	1.53.21.000001C	rear fender (black/grey stripe)	1		12	1.99.03.0502000	Hex Bolt inner M5*20	3	
3	1.99.27.100250S	Bolt M10×1.5×25	4		13	1.65.13.0500000	back rest side bracket	1	
4	1.53.21.000070C	Rear fender supports stand L b	1		14	1.63.13.0400000	Backrest pad	1	
5	1.01.21.000110N	Bolt M10*40	2		15	1.99.44.060000N	Nut M6	2	
6	1.99.43.0800000	Flange nut M8	4		16	1.57.09.0200200	rear anti-water plate	1	
7	1.53.13.0000100	sissy side bracket L	1		17	1.99.26.060120H	bolt M6×12	2	
8	1.99.27.080160N	Bolt M8 X 16	4		18	1.53.13.0000200	sissy side bracket R	1	
9	1.99.42.0800000	Nut M8(stainless)	4		19	1.57.09.0200300	rear anti-water fix plate	1	
10	1.56.11.0400200	Rubber strip,fuel tank cover	1						

F-17 接线盒盖与护板(Side cover and Wire box)

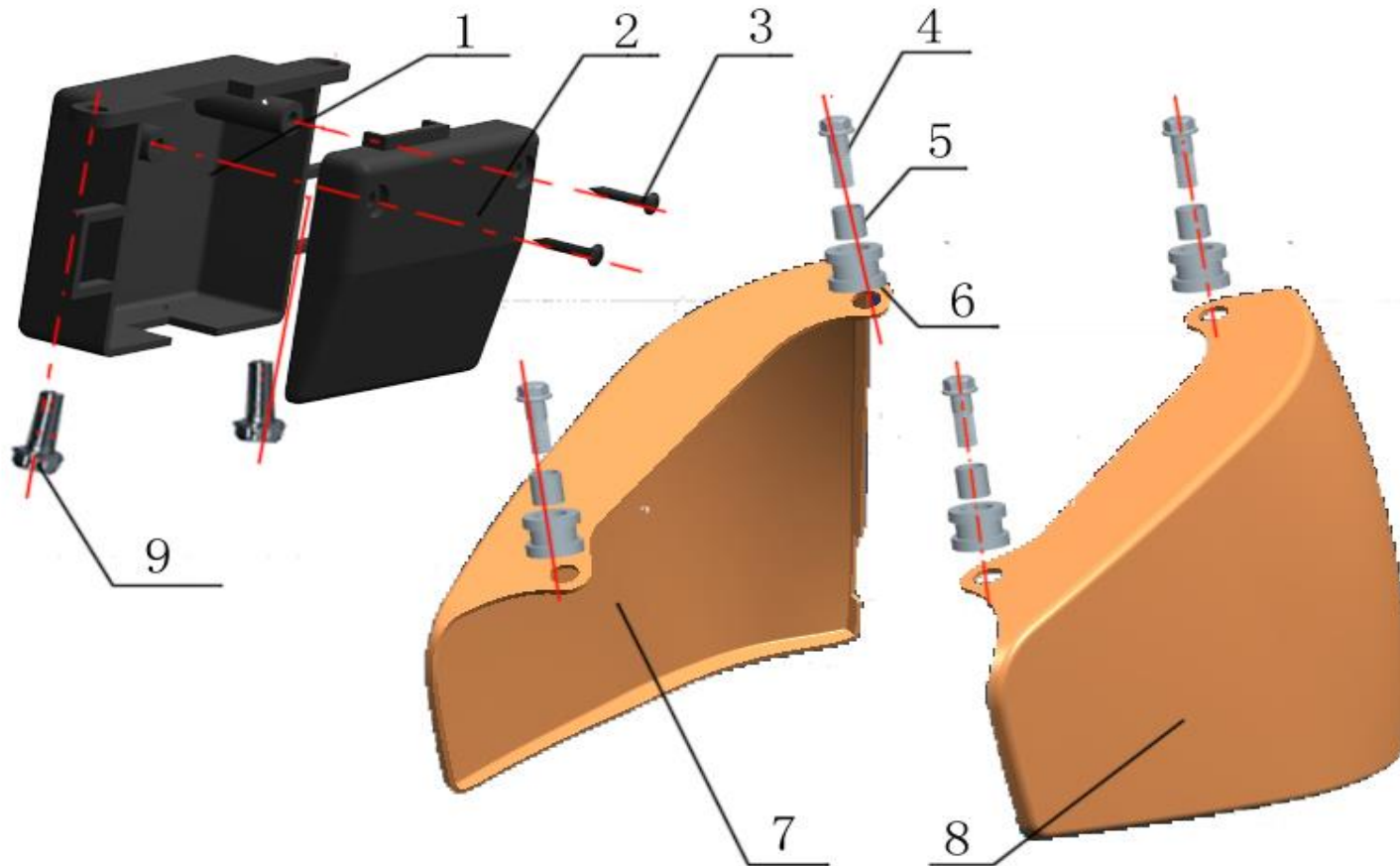

NO	PART CODE	DESCRIPTION	QTY
1	1.11.06.0000500	wire box	1
2	1.11.06.0000400	wire box cover	1
3	1.99.15.4202400	Self-tapping screwST4.2*24	2
4	1.99.04.060160N	screw M6 X 16	4
5	1.57.16.0100300	rubber ring	4
6	1.57.16.0100200	sleeve	4
7	1.57.16.010001C	left side cover(blk)	1
8	1.57.16.020001C	right side cover	1

F-18 后摇架及链条罩(Rear swing arm and Chain cover)

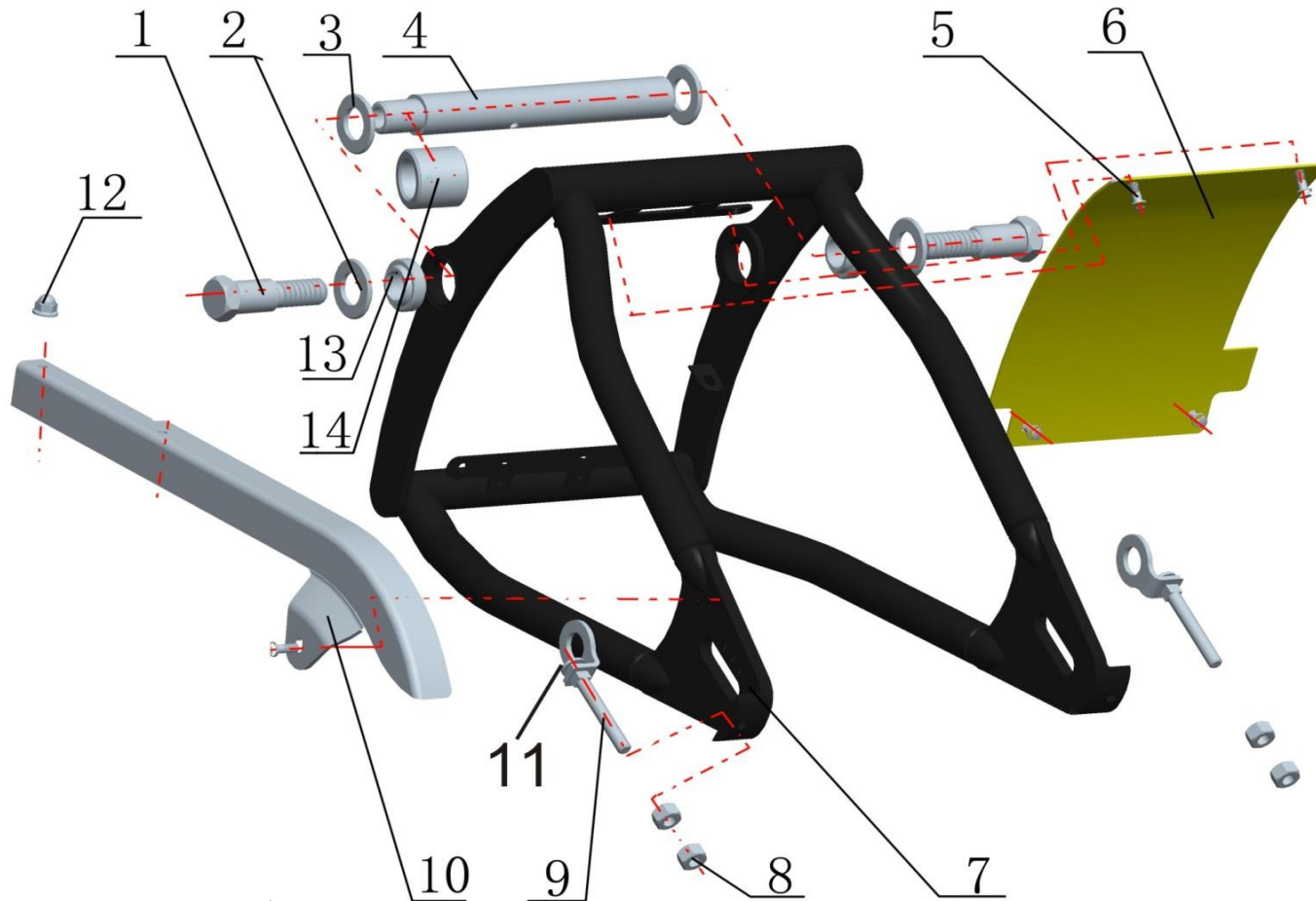

NO	PART CODE	DESCRIPTION	QTY	NO	PART CODE	DESCRIPTION	QTY
1	1.57.09.0000200	bolt, arm pivot shaft	2	8	1.99.42.0800000	Nut M8(stainless)	4
2	1.57.09.0000300	chain protect washer	2	9	1.63.10.0400100	Adjuster screw	2
3	1.57.09.0000500	spacer	2	10	1.57.09.0300000	chain cover	1
4	1.57.09.0010000	shake shaft	1	11	1.53.10.0400200	Adjuster block	1
5	1.99.26.060120H	bolt M6x12	4	12	1.01.09.0000900	Cap nut M5	2
6	1.57.09.0200110	rear fender	1	13	1.57.09.0000400	Bearing GE20ES	2
7	1.57.09.0100000	rear shaker	1	14	1.57.09.0010100	chain protect sleeve	1

F-19 副脚踏组件(Left & Right Passenger's pedal)

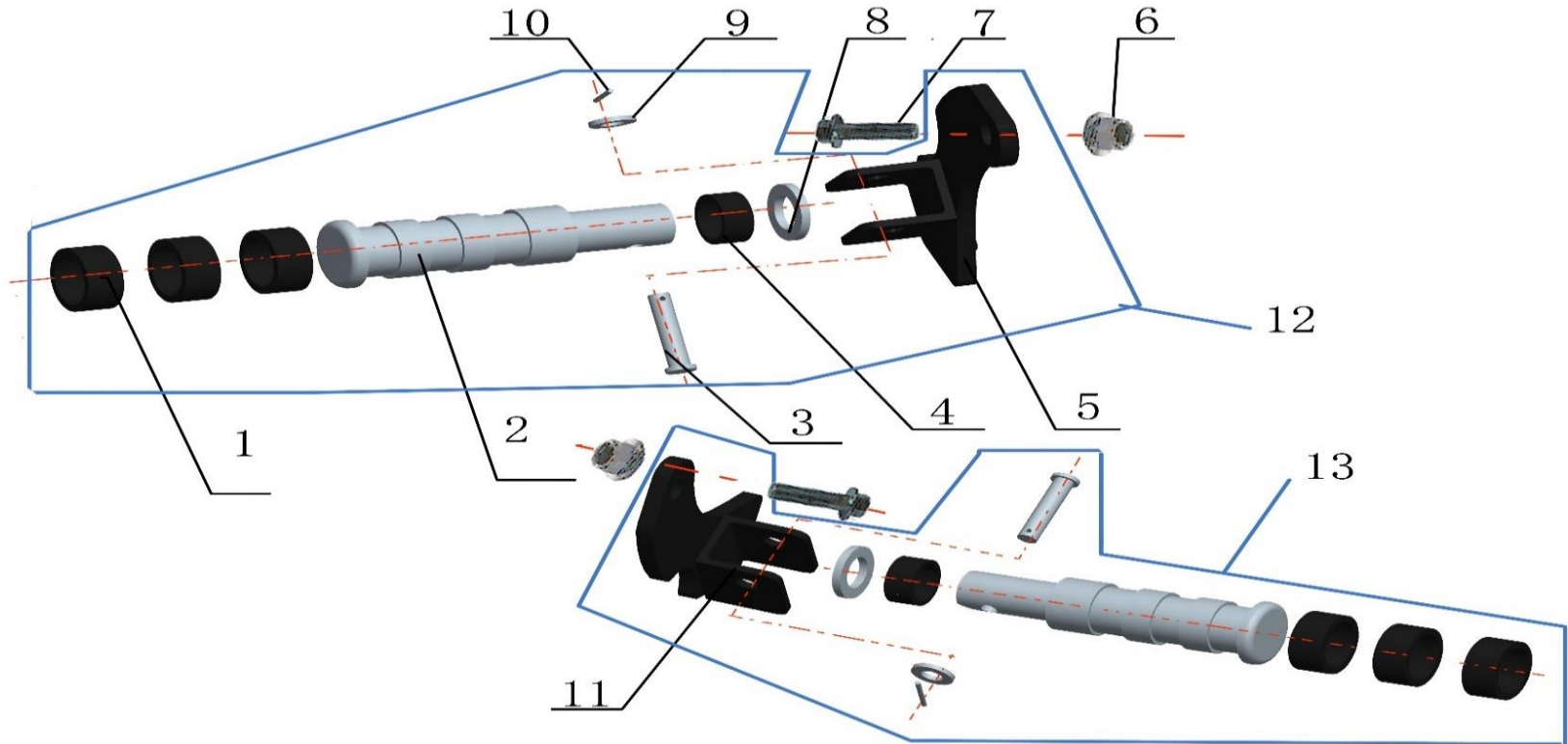

NO	PART CODE	DESCRIPTION	QTY
1	1.57.14.0230300	rubber (2)	6
2	1.63.19.1100300	passenger's pedal pole	2
3	1.99.61.060350S	pin shaft	2
4	1.57.14.0230300	rubber (2)	6
5	1.63.19.1320000	left pedal mounting plate	1
6	1.99.44.100000R	self lock Nut M10 X 1.25	2
7	1.99.26.1002500	Bolt M10 X 25	2
8	1.11.190200200	seal 22	2
9	1.99.52.080000R	seal 8	2
10	1.99.60.020200R	Open pin	2
11	1.63.19.1110000	right pedal mounting plate	1
12	1.63.19.111030R	left passenger's pedal	1
13	1.63.19.121030R	right passenger's pedal	1

F-20 副脚蹬组件(Kettle and Radiator)

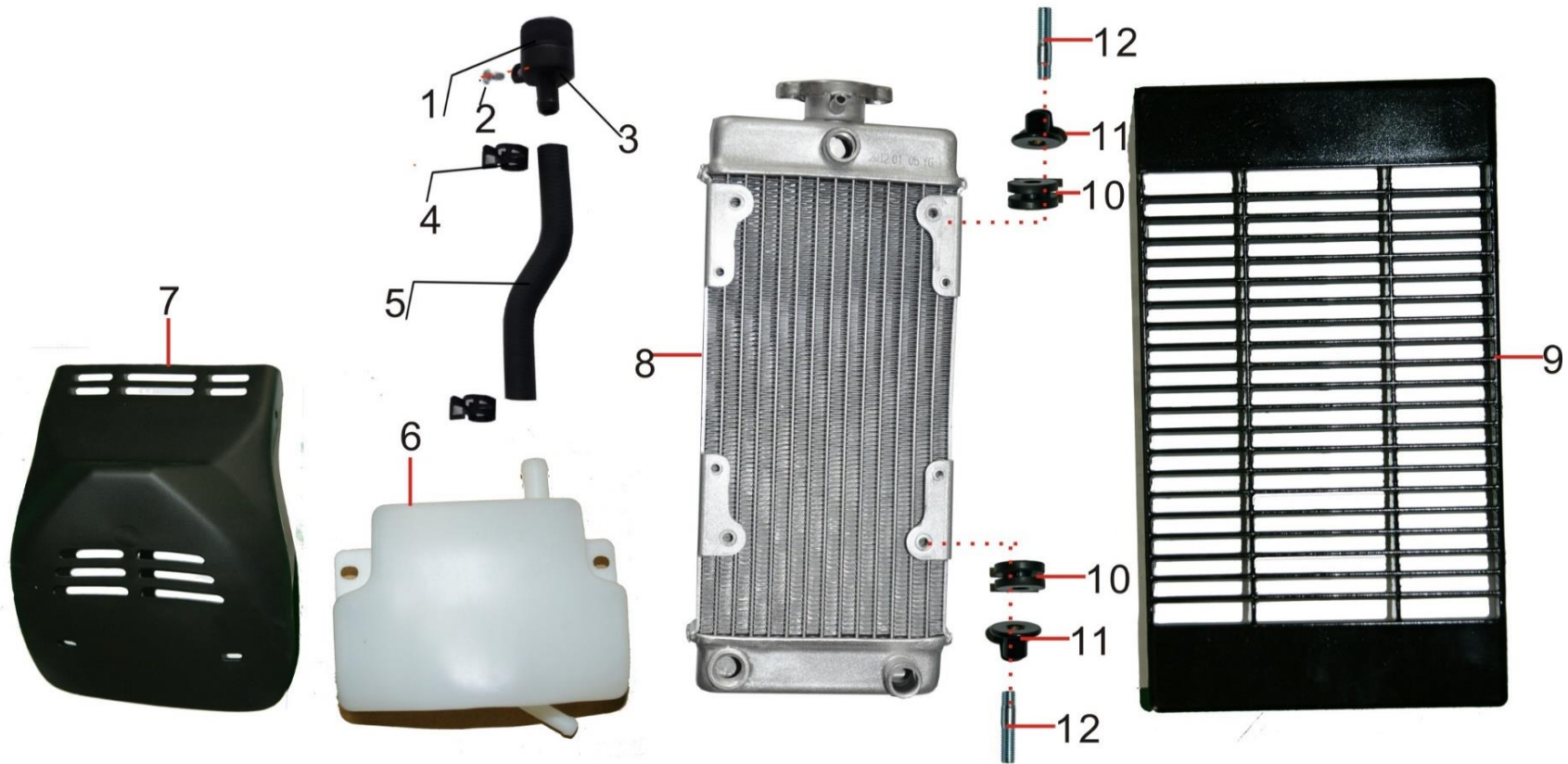

NO	PART CODE	DESCRIPTION	QTY
1	1.23.00.0000300	kettle cap	1
2	1.99.26.060120H	bolt M6x12	1
3	1.23.00.0000200	kettle top	1
4	1.23.00.0000500	Kettle pipe hoop	1
5	1.63.00.0000500	kettle filler hose	1
6	1.72.00.0000110	battery positve wire	1
7	1.72.00.0000200	battery positve wire	1
8	2.27.0117.11030	Radiator	1
9	1.63.00.0000400	radiator cover	1
10	2.24.0117.00700	Radiator Damping Washer	4
11	2.24.0117.00600	Radiator Damping washer steel	4
12	1.72.00.0000400	kettle	4

F-21 Engine Parts

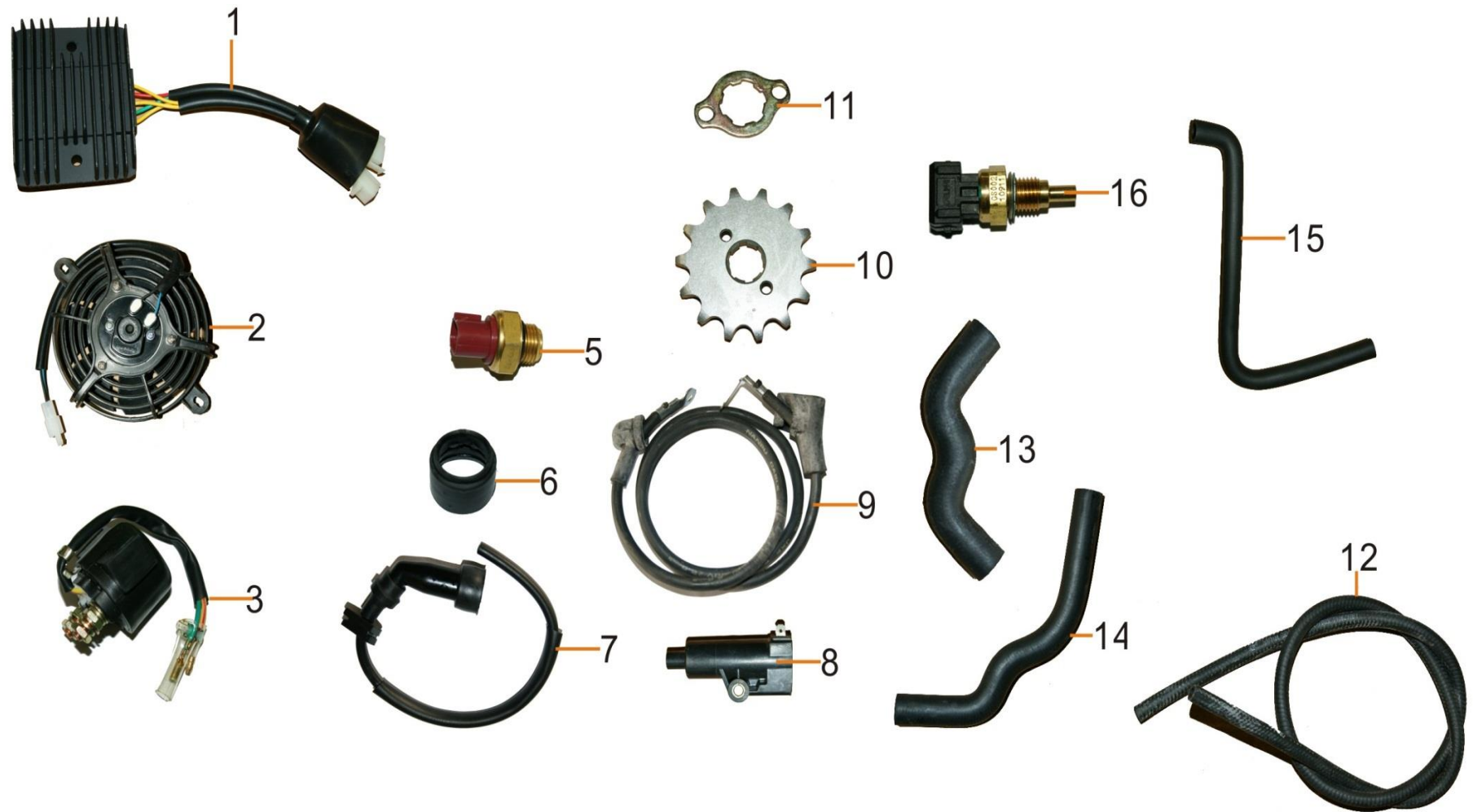

NO	PART CODE	DESCRIPTION	QTY	NO	PART CODE	DESCRIPTION	QTY
1	2.27.0111.40000	Rectifier assy DC	1	10	2.20.0114.40110	Sprocket,counter shaft(530)	1
2	2.24.0117.20030	Fan motor switch	1	11	2.20.0114.40200	Plate,fixing	1
3	2.20.0110.20000	Start magnetic	1	12	2.27.0117.00600	inlet water pipe	1
5	2.23.0117.12010	Fan motor switch	1	13	2.22.0107.00100	water pipe inlet	1
6	2.23.0117.12200	fan switch rubber seal	1	14	2.27.0117.00200	outlet water pipe	1
7	2.20.0111.30500	high damping line	2	15	2.22.0101.00220	waste pipe	1
8	2.22.0118.00400	ignition coil	2	16	2.24.0118.00200	water temperature sensor	1
9	2.25.0110.11000	Cable,starting motor	1				

END